



7000SM

# SewQuiet™ 750 Watt Servo Motor with Synchronizer

7000SM  
SewQuiet Servomotor  
Instruction Manual  
English



**Do Not Return To Store**  
**Contact Us First**

For immediate help with your purchase, please give us a call so that we can resolve your issue.

We can be reached toll-free at 1-800-268-1649 or email [support@reliablecorporation.com](mailto:support@reliablecorporation.com)

## Reliable. Getting it Right. For You.

At Reliable, we do what we love, and we take pride in doing it right. You want what's best for the people, places and things that matter in your life—from where you live to what you wear. So do we. That's why we approach every product with a laser-focus on you. In our commitment to quality, functionality, design and customer service, we are continuously innovating to find solutions to better fit your needs. Everything we make looks and feels just right, because it is. We get it right. For you.

For your safety and to fully enjoy the advantages of this product, please take a few minutes to read all the important safeguards and care instructions. Keep this manual handy and review the product warranty for your reference.

Thank you for your purchase. Please share your Reliable product experience by posting an online review on the website from which you purchased. We greatly appreciate it.

Scan the QR code or visit our support site to:

- Watch step-by-step how-to videos
- Access our FAQ
- Get troubleshooting tips



# Important Safety Instructions – Save These Instructions in a Safe Place For Future Reference

Read all instructions before use.

1. Do not press the pedal until you are ready to sew. Turn off the power before making any machine adjustments.
2. Do not remove or adjust the belt guard while the machine is powered.
3. Always turn off the power when changing the needle, threading the machine, or replacing the bobbin.
4. Disconnect the power plug before installation, removal, or maintenance.
5. Turn off the power before tilting or lifting the sewing machine.
6. Keep the product away from high-frequency electromagnetic sources or radio transmitters to prevent interference with the servo drive, which could cause malfunction.

## Important Information for Correct Disposal of the Product

This product must not be disposed of as urban waste. It must be taken to a special local waste collection centre or to a dealer providing this service.

# Specifications

**Electrical** 120V/Single Phase  
**Frequency** 50~60HZ  
**Motor torque** 3.7N.M

**Wattage** 750W / 1 Horsepower  
**Speed** 200 - 7000RPM

## Meet Your SewQuiet 7000SM

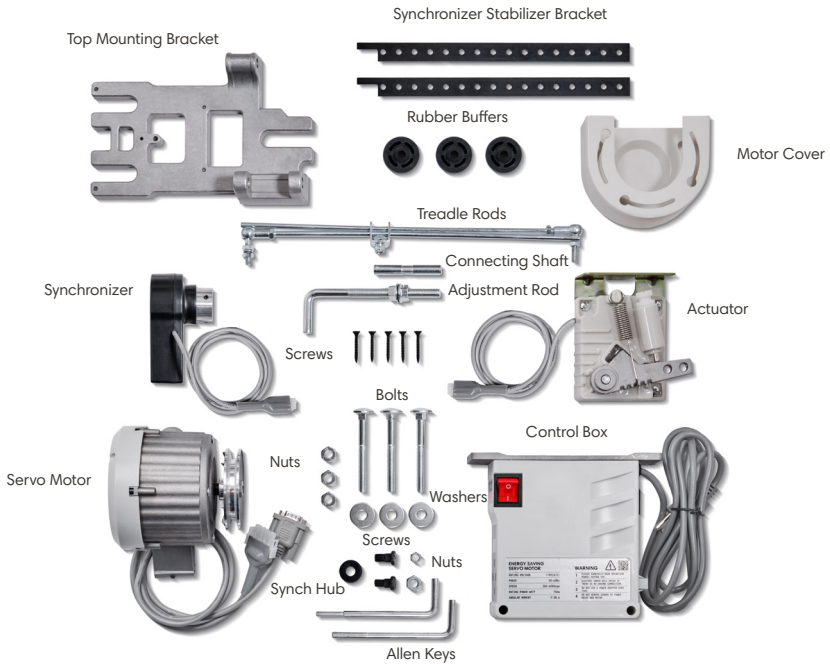

## Installing the Main Motor

There are many variations in sewing machine setups, so installation may differ depending on your model.

**For replacement installations:** Mount the motor in the same position and orientation as the original motor. This ensures compatibility with your existing setup.

**For new installations:** Refer to your sewing machine's manual for proper motor placement and mounting instructions specific to your machine model.

If you're unsure, consult a qualified technician to ensure safe and accurate installation.

# Assembling and Installing the Motor

## 1. Attach the Connecting Shaft

- Insert the connecting shaft through holes A and B to link the top mounting bracket with the motor body (Fig. 1).

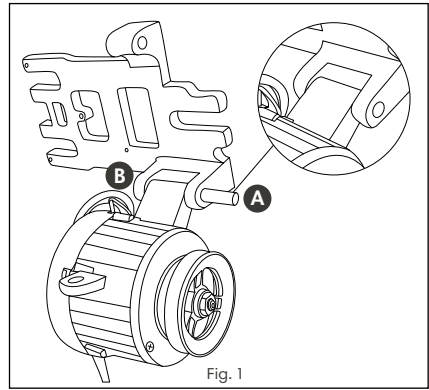

- Once in place, secure the connecting shaft using the rear set screw at position C (Fig. 2). Use an Allen key to tighten the screw firmly, ensuring there's no movement.

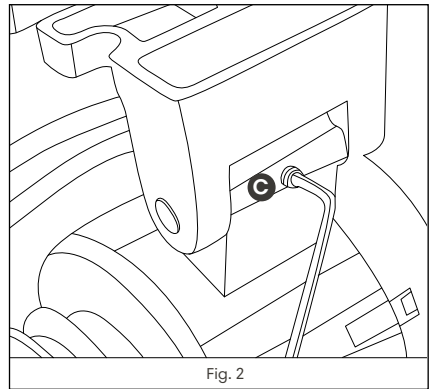

## 2. Install the Adjustment Rod

- Insert one end of the adjustment rod into hole D. This end will remain fixed (Fig. 3).

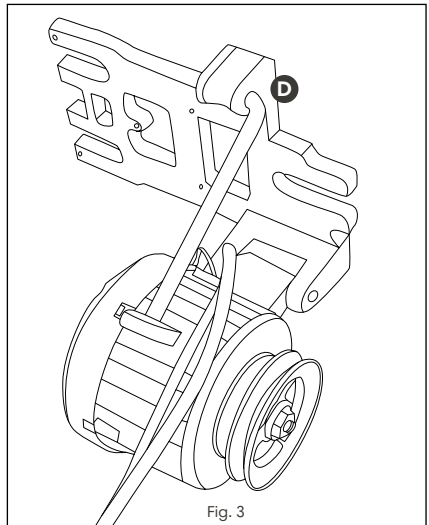

- Before inserting the threaded end into the adjustment rod support (E), screw one of the adjustment locking nuts onto the rod (Fig. 4).

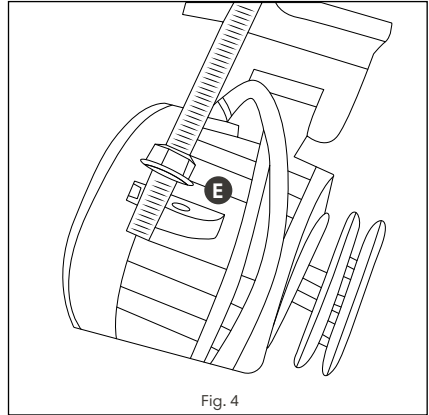

Fig. 4

- Insert the rod into adjustment rod support (E), then install the second locking nut on the other side.

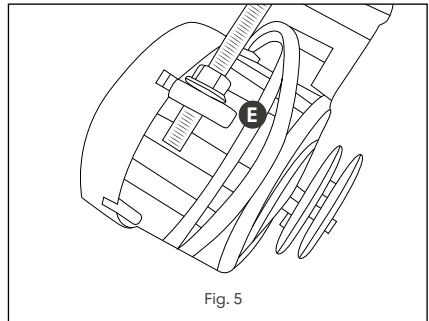

Fig. 5

- Tighten the top locking nut to adjust the tension on the belt. Then, secure by tightening the bottom locking nut. These locking nuts allow for fine-tuning of motor height and swing (Fig. 6).

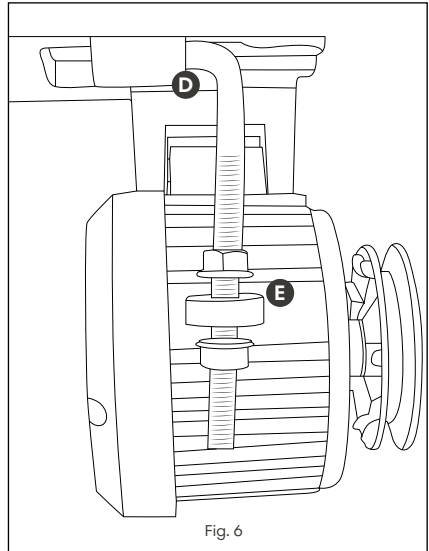

Fig. 6

### 3. Prepare the Table

- Ensure the underside of the sewing machine table is clean and free from obstructions (Fig. 7).
- Confirm that there is enough space beneath the table to accommodate the motor.

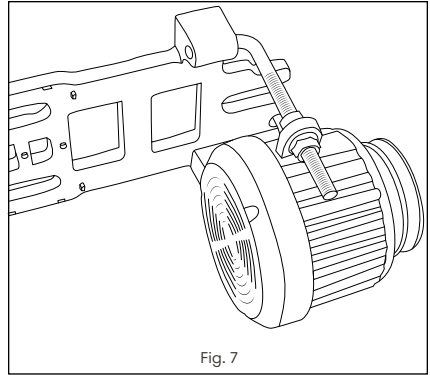

Fig. 7

### 4. Mount the Motor

- Locate the holes on the sewing machine table where the motor will be mounted using bolts. On a Reliable sewing machine, these holes are located behind the sewing machine head and are arranged in a triangular pattern. (Fig. 8)

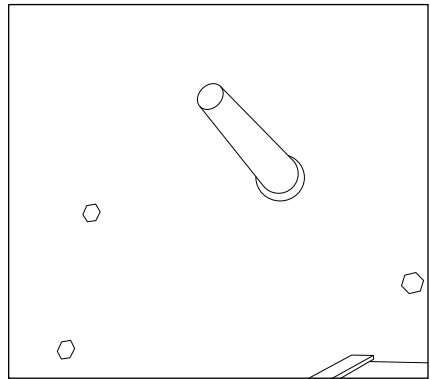

Fig. 8

- Insert the provided bolts into the mounting holes. From underneath the table, slide the rubber cushions onto the screws.
- Place the top mounting bracket over the screws, then tighten the washers to secure the bracket in place. ( Fig. 9)

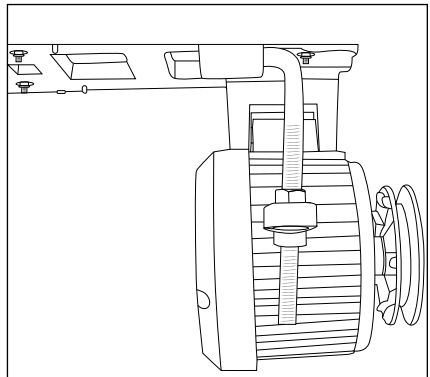
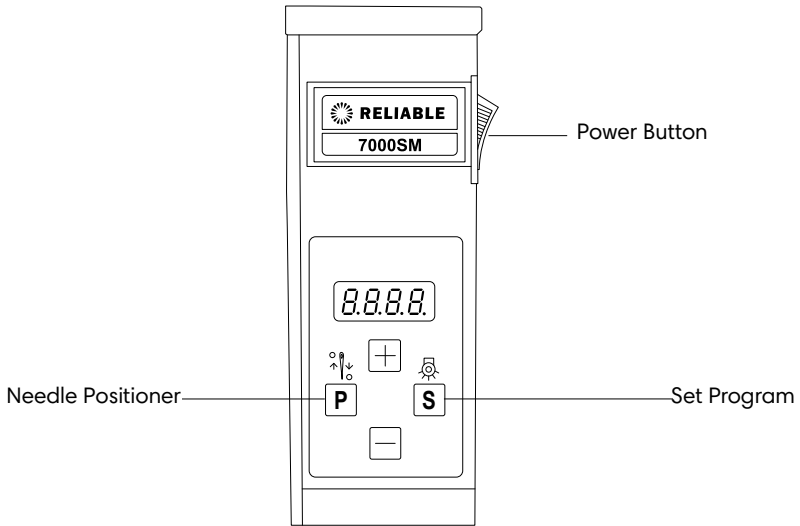

Fig. 9

# Control Box



## Installing the Control Box

To install the control box:

1. Identify the inside of the sewing machine leg, about 3 inches inside the table where the control box should be placed. This area will keep the control box protected from external damage and interference.
2. Mount the control box in place and using the screws provided — one at the front and one at the back.
3. Connect the cables to the back of the control box. Ensure each wire is correctly connected as incorrect connections could lead to malfunction or potential damage to the motor.

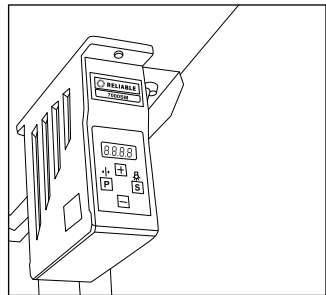
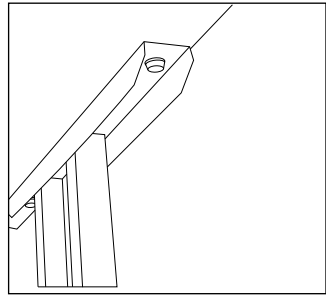

# Connecting the Control Box

Refer to the line art below to identify where each cable connects:

**Note:**

- The connection for the synchronizer cable is identical to the foot pedal/actuator cable. The synchronizer cable is plugged into the left port and the foot pedal/actuator cable is plugged into the right port.
- The 120V outlet has low amperage capacity and is rated for 3 amps.

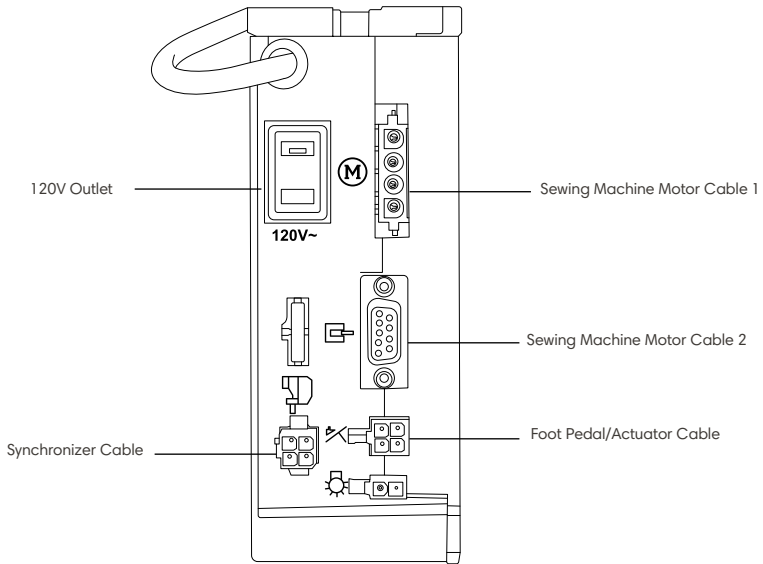

# Using the Control Box

This control system is designed for ease of use and high performance. It offers quick start and stop functions, accurate needle positioning, and intelligent safety features. The modular circuit includes a built-in self-protection system to guard against low voltage, overcurrent, and overheating. Sewing speed can be set by the control box and controlled via the foot pedal.

## Button Functions:

### 1. “P” Key – Needle Position & Function Mode

Press the “P” key to cycle through needle stop positions:

- Upper light on: Needle stops in the **up** position
- Lower light on: Needle stops in the **down** position
- Both lights off: Free stop mode (needle stops at random position)
- The “P” key is also used to enter the function parameter menu.

**Note:** Needle Position 7000SMSYNCH is required for needle position function.

### “S” Key – Confirmation

- The “S” key is used to confirm parameter changes in the function menu.

### 3. “+” and “-” Keys – Speed & Parameter Adjustment

Use these keys to:

- Adjust sewing speed.
- Navigate and modify settings in the function menu.

# Using the Needle Positioner

The Needle Positioner lets you choose where the needle stops when you stop sewing. You can set it to UP, DOWN, or OFF.

Button Functions:

## First Press – Needle UP

- The needle will stop in the raised (UP) position every time you stop sewing.
- The LED on the top-left of the button will light up.

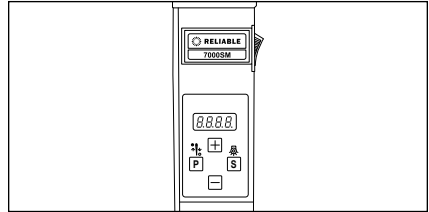

## Second Press – OFF

- Disables the Needle Positioner. The needle will remain wherever it stops.
- Both LEDs will be off.

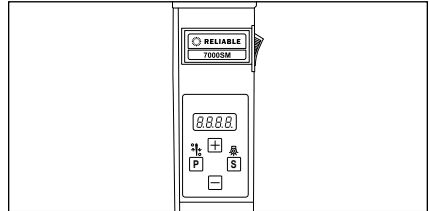

## Third Press – Needle DOWN

- The needle will stop in the lowered (DOWN) position every time you stop sewing.
- The LED on the bottom-right of the button will light up.

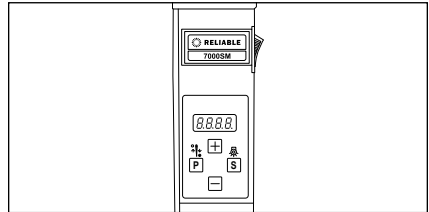

# Entering the Function Menu

## How to change motor rotation direction (clockwise ←→ counterclockwise)

1. Turn on the power.
2. Press and hold the “**P**” key, then press the “+” key. The screen will display **P-00**.
3. Use the “+” key to scroll to **P-02** (motor rotation direction setting).
4. Press the “**P**” key to select it. The screen will show a value:
  - **1** = clockwise rotation
  - **0** = counterclockwise rotation
5. Press the “-” key to change the value as needed.
6. Press the “**S**” key to save and exit.

| Parameter | Description              | Range                               | Default  |
|-----------|--------------------------|-------------------------------------|----------|
| P-01      | Maximum speed lock       | 200-7000 RPM                        | 4500 RPM |
| P-02      | Motor rotation direction | 0: Counterclockwise<br>1: Clockwise | 1        |
| P-03      | Needle stop angle        | 6°-18°                              | 12°      |
| P-15      | Detect needle position   | 0: No 1: Yes                        | 1        |

**Note:** Refer to your product manual or parameter chart for advanced options and recommended settings for your specific machine type.

# Connecting the Actuator to the Foot Pedal

To install the foot pedal:

## Assemble the Treadle Rods

- Join the treadle rods using the provided connection and nuts.
- Adjust the rods so there is no stress on the actuator lever.

## Connect the Treadle Rods with the Foot Pedal

- Secure one end of the treadle rod with the foot pedal. The other end will be connected with the actuator using the nuts and washers provided.

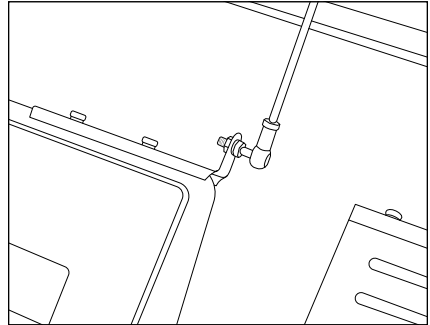

## Mounting the Actuator

- Mount the actuator under the sewing machine table using the screws provided.
- Secure it firmly on the underside of the table.
- Align the actuator based on where the foot pedal is installed on your machine.

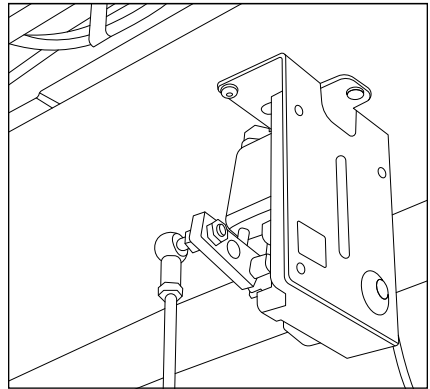

## Final Check

- Once done, check if all the connections are secure and the pedal operates as intended.

# Troubleshooting the Error Codes

| Error | Cause                         | Solution  |
|-------|-------------------------------|---|
| ER01  | Cannot detect needle position | <ul style="list-style-type: none"> <li>• Handwheel is not close enough (gap &gt; 2.5mm)</li> <li>• Poor connection on 9-pin plug</li> <li>• Faulty hall sensor</li> <li>• Magnet on handwheel is missing</li> </ul> |
| ER02  | Speed controller not detected | <ul style="list-style-type: none"> <li>• Controller plug is not inserted</li> <li>• Speed controller cable is damaged or loose</li> </ul>   |
| ER03  | Hall sensor or phase error    | <ul style="list-style-type: none"> <li>• Bad 9-pin connection</li> <li>• Improper motor installation</li> <li>• Faulty hall sensor</li> </ul>   |
| ER04  | Locked rotor protection       | <ul style="list-style-type: none"> <li>• Motor overload</li> <li>• Loose 4-wire connection between motor and controller</li> <li>• Motor damage</li> </ul>  |
| ER05  | Over-current protection       | <ul style="list-style-type: none"> <li>• Motor overload</li> <li>• Signal cable issue</li> <li>• Damaged main board</li> </ul>  |
| ER07  | Serial communication timeout  | <ul style="list-style-type: none"> <li>• Poor signal connection between display and main board</li> <li>• Faulty main board</li> </ul>  |
| —     | Display off, switch has power | <ul style="list-style-type: none"> <li>• Display or main board failure</li> <li>• Loose display-to-board cable</li> </ul>   |

# Restoring Factory Settings

To reset the system to factory defaults:

1. Press and hold the **"P"** key.
2. While holding **"P"**, press the **"+"** key. The screen will display **P-00**.
3. Press and hold the **"S"** key for approximately 3 seconds to restore default settings.

# Installing the Synchronizer

## Accessories

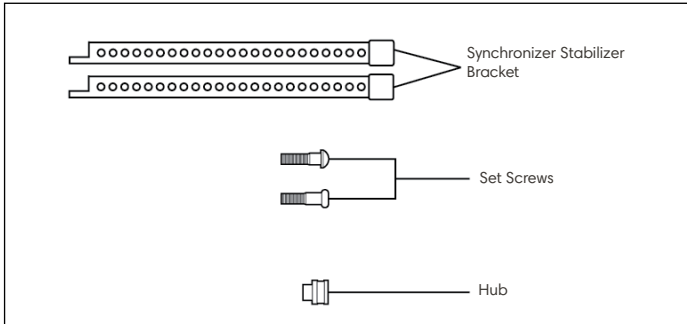

**Note:** The two metal brackets provided are adjustable and may need to be bent to fit or align correctly. Use both for offset positions or just one, if a direct mount is possible.

To install the synchronizer:

1. Remove the screw from the upper hand wheel by turning it counterclockwise.

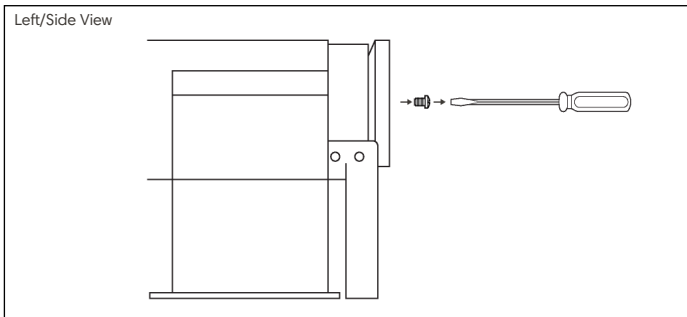

2. Install the synchronizer hub using one of the two set-screws (dependant on model) provided.

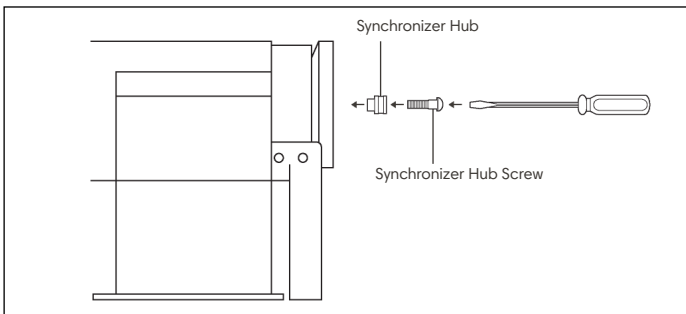

3. Mount synchronizer onto the hub and slightly tighten the three screws.

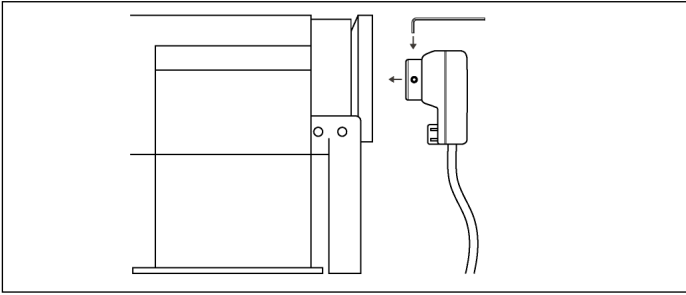

4. You must decide where it's best suitable to mount the synchronizer stabilizer bracket because the positioning won't be the same for all makes and models. Use both brackets for offset positions or just one if a direct mount is possible.

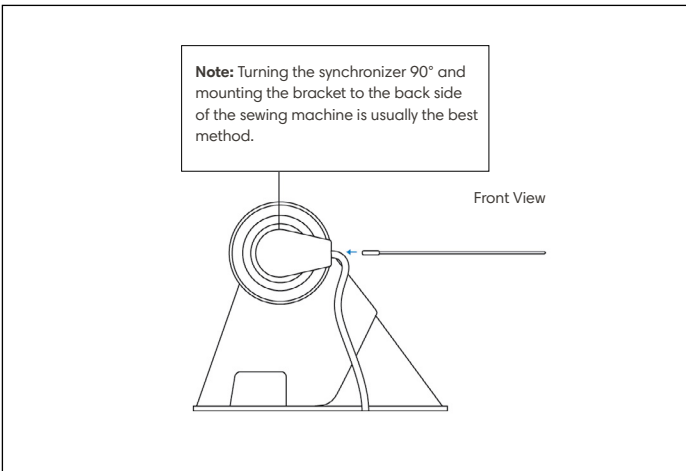

5. Once you have the synchronizer stabilizer bracket in place securely tighten the screws.

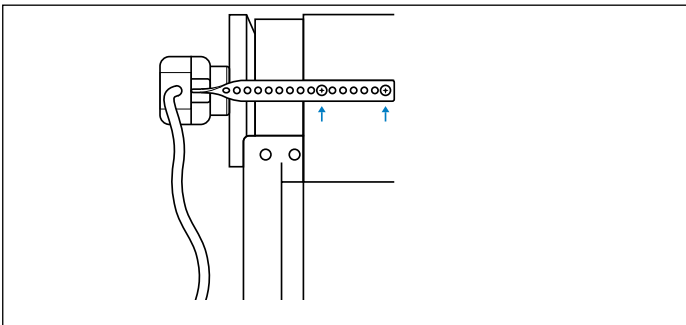

6. You might have to drill 5/8" to the far back of the machine's table top to pass the synchronizer cable through to the motor.

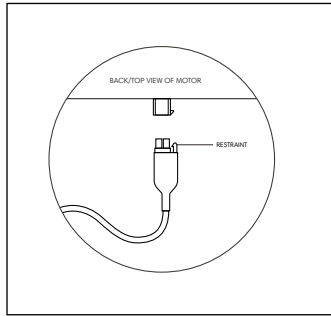

Reliable Corporation ("Reliable") warrants to original purchaser of its products that every product sold by Reliable (a "Reliable Product") is free from defects in material and workmanship for a period of one year from the date of purchase if properly used and maintained. Subject to the conditions and limitations set forth below, Reliable will either repair or replace any part of a Reliable Product that proves defective by reason of improper workmanship or materials. If the defective Reliable Product is no longer available and cannot be repaired effectively or replaced with an identical model, Reliable shall replace the defective Reliable Product with a current Reliable Product of equal or greater value. Repaired parts or replacement products will be provided by Reliable on an exchange basis, and will be either new or refurbished to be functionally equivalent to new. If Reliable is unable to repair or replace a Reliable Product, it will refund the current value of that Reliable Product at the time the warranty claim is made.

This limited warranty does not cover any damage to a Reliable Product that results from improper installation, accident, abuse, misuse, natural disaster, insufficient or excessive electrical supply, abnormal mechanical or environmental conditions, wear and tear resulting from normal use of the product, or any unauthorized disassembly, repair, or modification. This limited warranty does not extend to any indirect, consequential or incidental damages that may be suffered by a user or from the use of a Reliable Product, including without limitation, any liability for third party claims for damage, and is limited to the amount paid by the original purchaser Reliable Product with respect to which this limited warranty protection applies. This limited warranty does not apply with respect to products that have been altered or which are missing serial numbers or for products not purchased directly from Reliable or a dealer authorized by us to sell Reliable Products.

This limited warranty is the only warranty that applies to any Reliable Product, supersedes any and all terms that may be contained in any other document or purchase order and may not be altered or amended except expressly in writing by Reliable.

To obtain a repair or replacement under the terms of this warranty, please contact our customer service group at 1-800-268-1649 or at [support@reliablecorporation.com](mailto:support@reliablecorporation.com).

You will be required to submit an original receipt via fax or e-mail. The receipt must reflect that you are the original purchaser, the product was bought directly from us or from an authorized Reliable dealer and that the warranty claim is being made within the warranty period. You will be issued a return authorization number (RA#) and asked to ship the defective product together with proof of purchase and RA#, prepaid insured to the following address:

Reliable Corporation, 5-100 Wingold Avenue, Toronto, ON M6B 4K7. Freight collect shipments will be refused. The risk of loss or damage in transit will be borne by the customer. Once Reliable receives the defective product, it will initiate the repair or replacement process.

If you have any questions regarding this warranty, you may write to:

Reliable Corporation  
100 Wingold Avenue, Unit 5  
Toronto, Ontario  
Canada M6B 4K7  
[www.reliablecorporation.com](http://www.reliablecorporation.com)



1 800 268 1649  
[www.reliablecorporation.com](http://www.reliablecorporation.com)

08102025