



7220DB

INDUSTRIAL DRAPERY BLINDSTITCH MACHINE
INSTRUCTION MANUAL

< INSTRUCTION MANUAL >

INDEX

1. Unpacking Machine	1
2. Setting-up Machine.....	1
3. Handwheel Rotation and Speed.....	1
4. Oiling and Maintenance.....	1
5. Replacing Needle.....	2
6. Threading Machine.....	3
7. Inserting the Work and Starting to sew.....	4
8. Adjustment of Needle Penetration.....	4
9. Stitch Length Regulation.....	5
10. Needle Recommendation.....	5
11. Skip Stitch Device	6
12. Removal of the Work from the Machine	6
13. Cloth Retainer Spring Adjustment (for H-101-H).....	7
14. Stitch Stabilizing Guide (for H-1012).....	7
15. Safety Instructions.....	8
16. Technician Model Parameter Diagram	9
17. Fault Solution Guide	10

1. Unpacking Machine

Open packing box by carefully removing its cover so as not to damage the machine or those of its parts which project from the top, such as the tension parts.

Small accessory parts are packed separately in individual packages. Do not discard any packing materials without prior scrutiny as to contents.

Clean from machine all greases, dirt or dust. Pay particular attention to area around the looper mechanism and looper.

2. Setting-up Machine

Assemble knee lifter lever to machine and place on sewing table so that lever is 13m distant from front edge of the table.

Mark three screw holes for fastening machine to sewing table and place felt pad under machine bed before machine is tightened down.

3. Handwheel Rotation and Speed

Turn handwheel only in direction away from operator for clockwise rotation. Be sure motor drive is wired up to obtain the same clockwise rotation. The recommended operating speed is 1000 RPM.

4. Oiling and Maintenance

It is important not to operate the machine before oil of good quality has been filled in each and every oil hole along the top of the machine. When breaking-in a new machine oiling should be done sparingly several times a day. Thereafter, one oiling daily will be sufficient. After oiling, wipe machine carefully to avoid soiling of the material.

Do not operate without material under the presser foot unless the knee lever is depressed. This will prevent damage to the needle and the feed dog as well as the feed plattens.

5. Replacing Needle

Turn handwheel away from operator (clockwise) until needle reaches the end of its return stroke (extreme left hand position). Adjust penetration dial to least amount of penetration (turn clockwise towards 1).

Remove old or defective needle by loosening needle clamp screw. Insert new needle into seat in needle clamp as far as it will go. Tighten needle clamp screw.

Turn handwheel slowly away from operator and observe movement of needle. The curved portion of the needle should bear slightly on the needle guide groove in the left hand part of the presser foot.

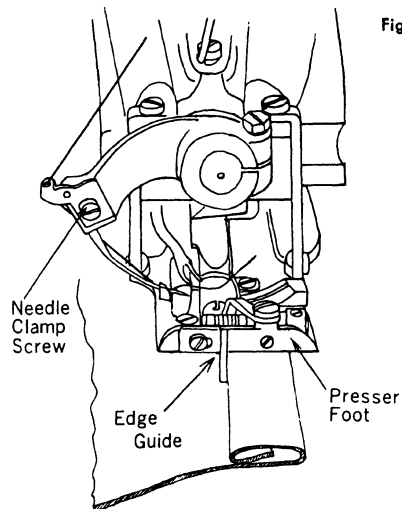

Fig. 1

Always replace bent or blunt needles. They affect the satisfactory operation of the machine. (see Fig. 1)

See par. 10 concerning needle sysetm to be used in Blindstitch Machines.

6. Threading Machine

Turn handwheel of machine in clockwise direction away from operator until needle carrier reaches its furthest lefthand position.

And proceed as follows :

Draw thread from spool on thread stand and pass it through thread guide (A) which is located on rear side of thread nipper.

Place thread between tension discs of thread nipper and thread tension and lead it forward through thread guide (B) and pass it through thread guide (C) at the top of the arm near its front.

From there pass thread through hole in needle clamp and then through the eye of needle from below upward. Pull about 5 cm of thread through the eye of needle. (see Fig 2)

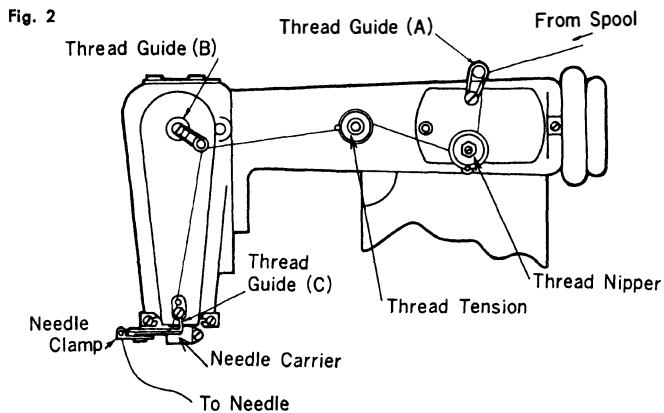

7. Inserting the Work and Starting to Sew

Depress knee lifter. This causes the feed plate to swing downward and creates a gap between the presser foot and the feed plate.

Insert the work in the gap just opened in such a manner that the folded or sewn edge of the material is alongside the edge guide of the presser foot. (see Fig. 1)

When the material is in proper position, completely release the knee lifter. Get the machine started slowly and watch the material pass edge guide rather than to observe the action of the needle.

8. Adjustment of Needle Penetration

The type of material to be blindstitched governs the degree of needle penetration which is required. It is, therefore, recommended to stitch a few centimeters as a test and make adjustments for penetration depending on the appearance of the trial stitching.

Turn regulator clockwise for less penetration and counter-clockwise for more penetration. (Fig. 3)

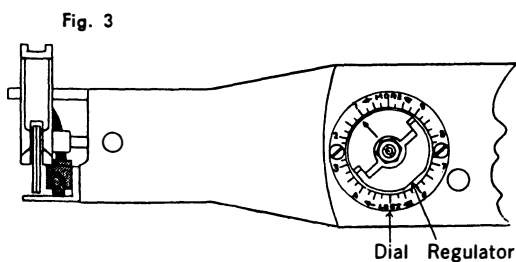

9. Stitch Length Regulation

Stitch length adjustment can be easily effected by adjusting needle driving eccentric in arm.

Go about it as follows:

Turn handwheel by hand pushing plunger until same is felt to drop into a recess within the mechanism inside the arm of the machine.

With the plunger remaining depressed into this recess continue turning the handwheel either forward or in reverse until the desired number of stitches per inch is visible on indicator. (see Fig. 4)

Fig. 4

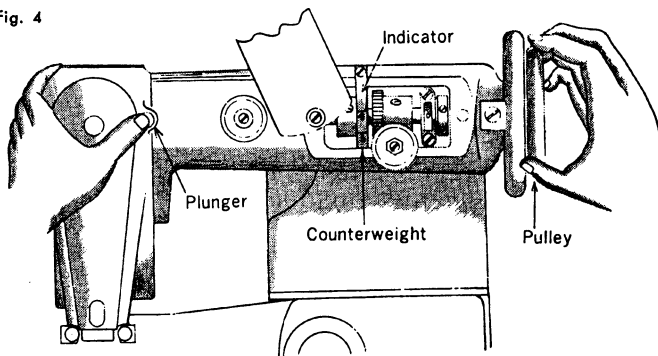

10. Needle Recommendation

The recommended needle is system LW x 6T.

Size	Material
3 (11)	Cottons. Silks. Acetates, Orlon, Dacron and similar type of light weight fabrics.
3 1/2 (14)	Medium weight materials. Woolens and Others.
4 (16)	Thick materials for coats, house furnishings.

11. Skip Stitch Device

The position of grip at the right side of the machine controls the skip stitch device. (see Fig. 5)

When this grip points towards NO SKIP, the needle catches the material at each stitch. Pointing towards SKIP, the needle penetrates the material at every other stitch.

Be sure that grip is pushed completely in either direction and needle penetration readjusted every time operation is changed from skip to nonskip.

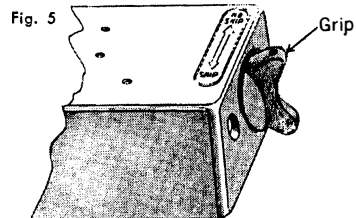

12. Removal of the Work from the Machine

Stop machine and turn handwheel away from operator until needle is completely out of the material. Press the knee lifter to the right and pull the work-piece rearward out of the machine with a quick stroke. This will lock the last stitch and break the thread.

13. Cloth Retainer Spring Adjustment (for H-101-H)

The tension of cloth retainer spring can be adjusted by turning the cloth retainer spring adjusting screw (see Fig. 6)

To increase the tension of cloth retainer spring, turn this screw to the right (clockwise). It is suitable for thicker material.

To decrease the tension, turn this screw to the left (counter-clockwise). It is suitable for thinner material.

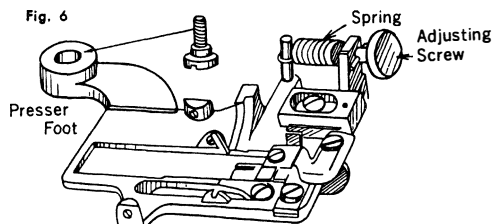

14. Stitch Stabilizing Guide (for H-10I2)

Stitch Stabilizing Guide is effective for soft and uniform stitch on extremely thin material.

If required tight stitch on thin and medium materials, loosen Stitch Stabilizing Guide Set Screw to take off Stitch Stabilizing Guide.

Be sure to tighten Stitch Stabilizing Guide Set Screw firmly on presser foot of same position after took off the Stitch Stabilizing Guide. (Ref. Fig. 7)

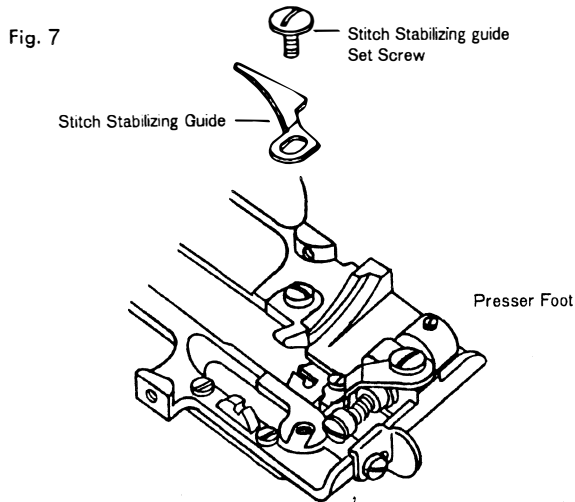

CAUTION: Please take good care not to lose Stitch Stabilizing Guide after took off.

1. SAFETY INSTRUCTIONS:

- 1.1. Instruction and trial-run must be done by professional technician;
- 1.2. Please ensure the grounded wire is working well;
- 1.3. Do not step on the foot pedal when motor turns on;
- 1.4. Control box and motor cover are forbidden to be opened when power turn-on;
- 1.5. Please ensure power is off during below operations:
 - a) When threading, changing needle and inner stitching thread;
 - b) When installing machine and maintaining;
 - c) When turning over the machine.

2. OPERATION PANEL INSTRUCTIONS:

2.1. Each Key purpose:

KEY	SEWING MODEL	FUNCTION MODEL
P	Needle position choice	Set Up, Down or turn Off Needle Position
S	Save parameter	Confirm the parameter setting.
+	Sewing speed-up	Key to add parameter and index.
-	Sewing slow-down	Key to reduce parameter and index.

2.2. ADJUSTING TECHNICIAN MODEL PARAMETER:

- a) Press key "P", meanwhile press key "+" once, the screen will show P-OO;
- b) Press key "+" or "-" till the parameter model number required;
- c) Press key "P" into parameter, the screen will show the parameter;
- d) Press key "+" or "-" till the required parameter;
- e) Press key "S" to save parameter and quit.

2.3. RESTORE FACTORY SETTING:

Press key "P", meanwhile press key "+", the screen will show P-00;
Then press key "S" 3 seconds, it will resource factory settings.

3. TECHNICIAN MODEL PARAMETER DIAGRAM:

Parameter Code	Description	Adjusting Scope	Factory Setting	Remark
P-02	Direction of rotation	0: Reverse turn 1: Clockwise turn	1	
P-03	The needle Angle	6-18	12	
P-04	Sewing-begin speed	200-800rpm	250	
P-05	Speed-up and slow-down	300-1200	850	
P-06	Setting the seam	0-999needle	0	
P-07	Reserve			
P-10	Automatic clearance run	0: normal sewing 1: automatic clearance run	0	Turn off power, running stop
P-14	Maximum current limit	50-500	300	
P-15	The location of topper needle	0: No detecting 1: Detecting needle	1	

4. FAULT SOLUTION

Error Code	Content	Reason
Er01	No found needle position	The gap between handle wheel and motor cover is too big; Nine plug does not connect well; Motor hall broken, it should change new motor; The magnet in handle wheel is lost.
Er02	The speed regulator is not found when power-on	Speed regulator plug not plug-in or badly connected; The speed regulator wire is broken.
Er03	Motor hall or phase error	Nine plug not connected wall; Motor not installed well; Hall broken.
Er04	Lock-rotor protection	Motor overloaded; Motor is not well connected.
Er05	Hardware over-current protection	Motor overloaded; Signal wire badly connected or broken.
Er07	Serial port communication timeout error	The wire between display and main board is not good or main board broken.

PARTS BOOK

MOTOR - Direct Drive Motor

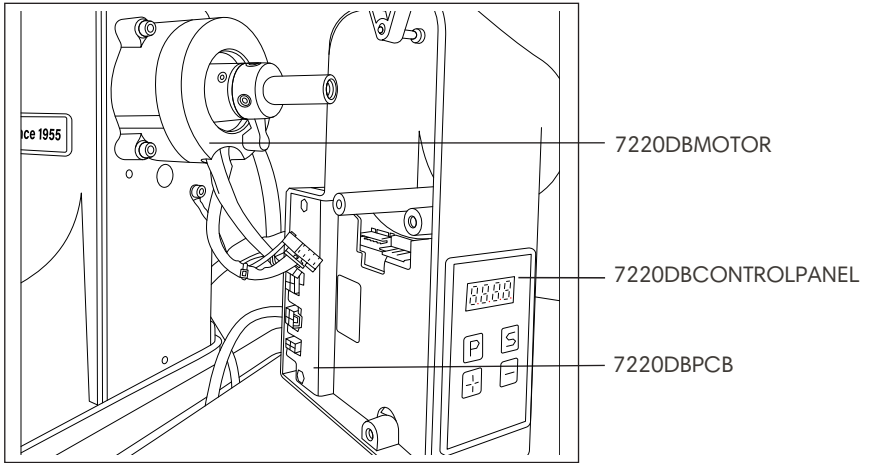

Actuator- 7220DBACTUATOR

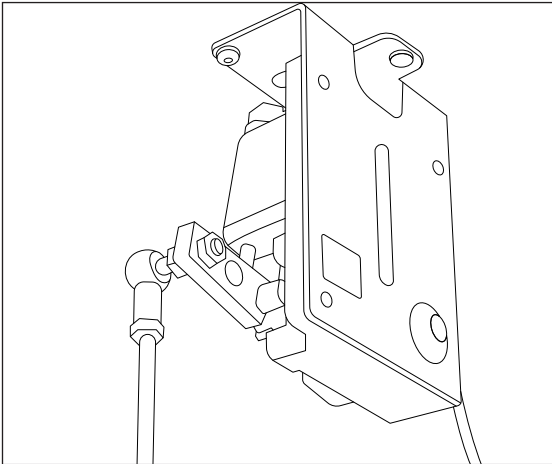

Treadle Rods- GEN143UOS

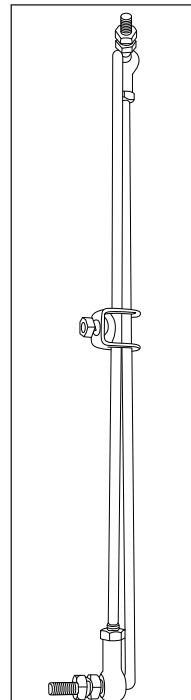

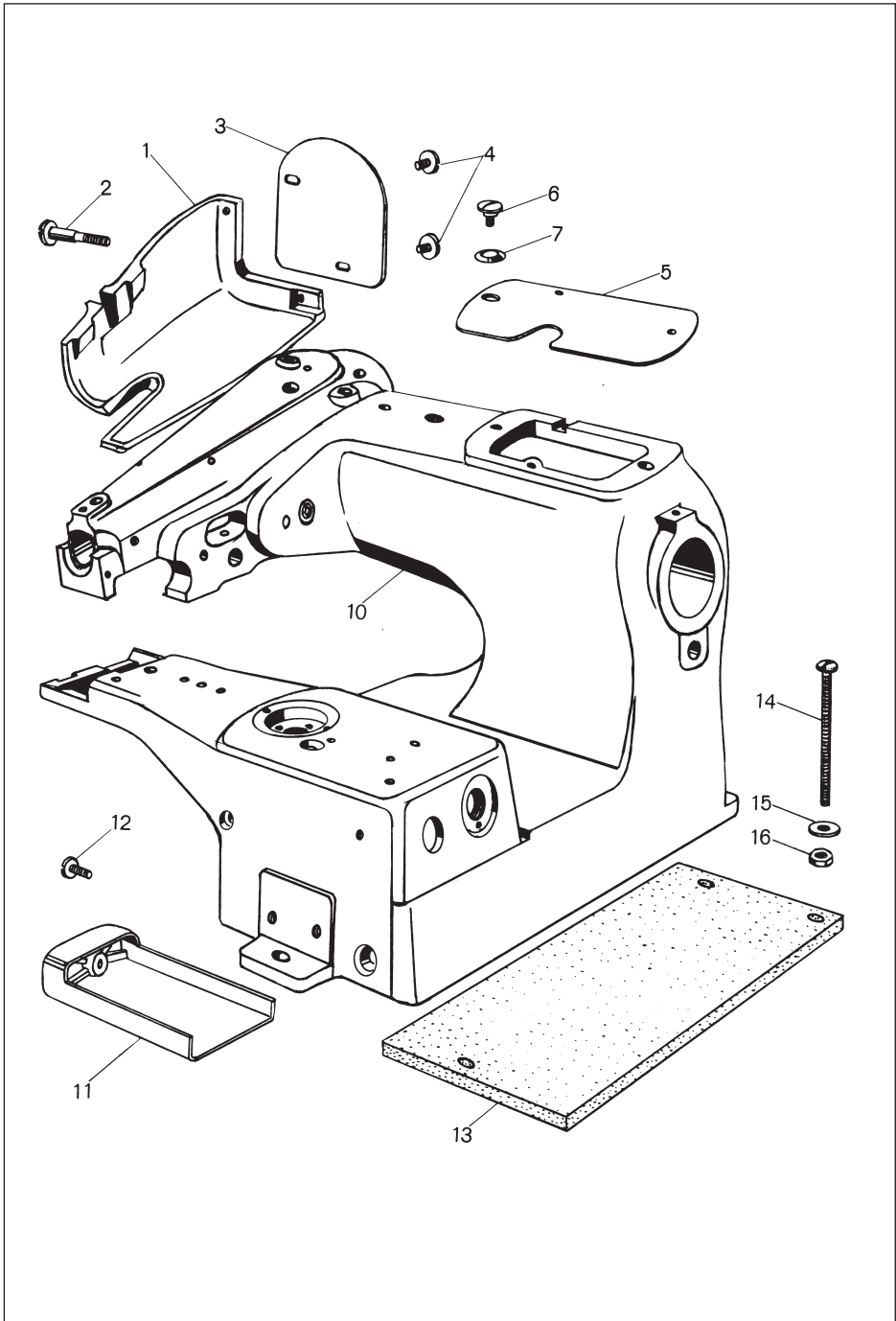

Machine Frame & Covers Components

Ref. No.	Parts No.	Description
1	4139	Arm Side Cover
2	4144	Arm Side Cover Set Screw
3	4137	Arm Side Cover Plate
4	5227	Arm Side Cover Plate Screw
5	4138-B	Arm Top Cover Plate
6	4141	Arm Top Cover Plate Screw
7	4140-A	Arm Top Cover Plate Washer
10	AM100-B	Machine Frame
11	11091	End Cover
12	11153	End Cover Set Screw
13	4214	Machine Base Felt Pad
14	AC-15	Machine Base Clamp Screw
15	AC-17	Machine Base Washer
16	AC-16	Machine Base Nut

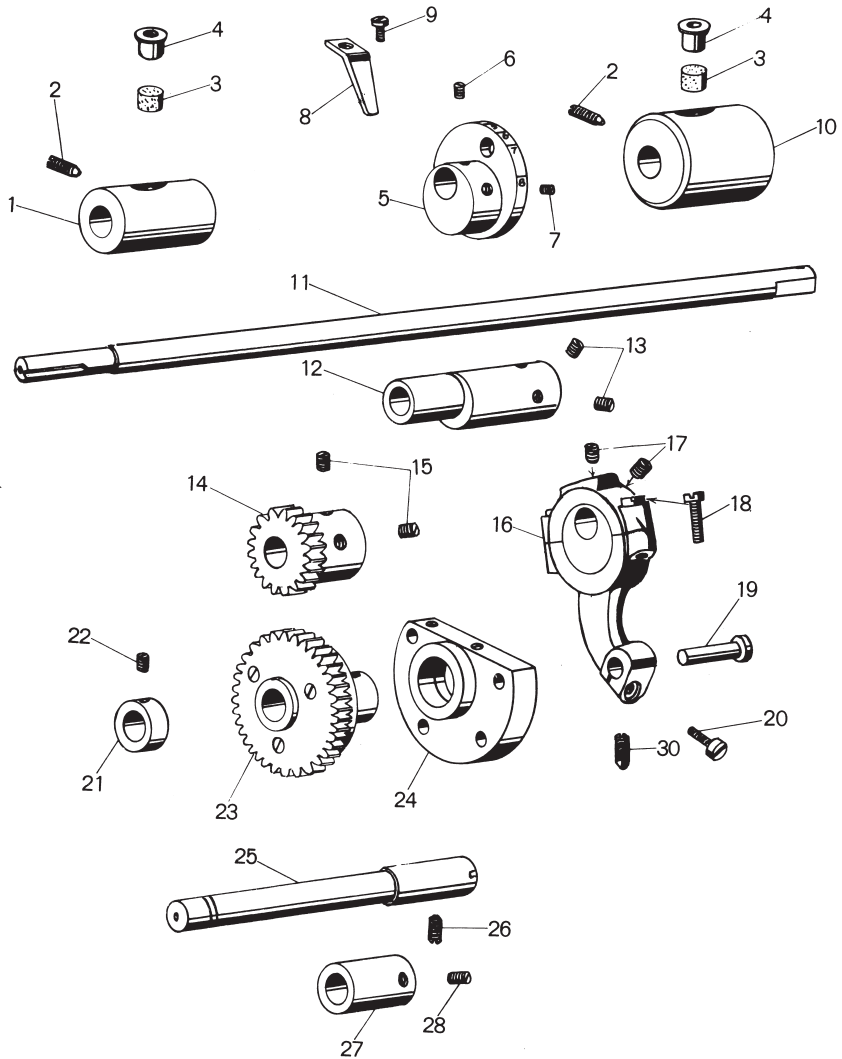

Main Shaft Mechanism Components

Ref. No.	Parts No.	Description
1	11005	Main Shaft Bushing (Front)
2	131	Main Shaft Bushing Set Screw
3	4217	Oiling Felt
4	4128-A	Oil Cap
5	4133	Counterweight (w/Stitch Length Numbers)
6	132	Counterweight Set Screw (Short)
7	98	Counterweight Set Screw (Long)
8	4134	Stitch Length Indicator
9	124	Stitch Length Indicator Set Screw
10	11006	Main Shaft Bushing (Rear)
11	4003-A	Main Shaft
12	6048	Thread Tension Releasing Eccentric
13	96	Thread Tension Releasing Eccentric Set Screw
14	4162	Skip Stitch Gear (Small)
15	96	Skip Stitch Gear Set Screw
16	525-A	Eccentric Rod Assembly (w/Ref. Nos. 17, 18)
17	98	Eccentric Bushing Screw
18	105	Eccentric Rod Set Screw
19	4065	Eccentric Rod Stud
20	114-B	Eccentric Rod Stud Set Screw
21	4077-A	Skip Stitch Gear Shaft Collar (Small)
22	132	Skip Stitch Gear Shaft Collar Set Screw
23	4163	Skip Stitch Gear (Large) Assembly
24	4164	Eccentric Rod Connection
25	4166-A	Skip Stitch Gear Shaft
26	131	Skip Stitch Gear Shaft Set Screw
27	4168	Skip Stitch Gear Shaft Collar (Large)
28	132	Skip Stitch Gear Shaft Collar Set Screw

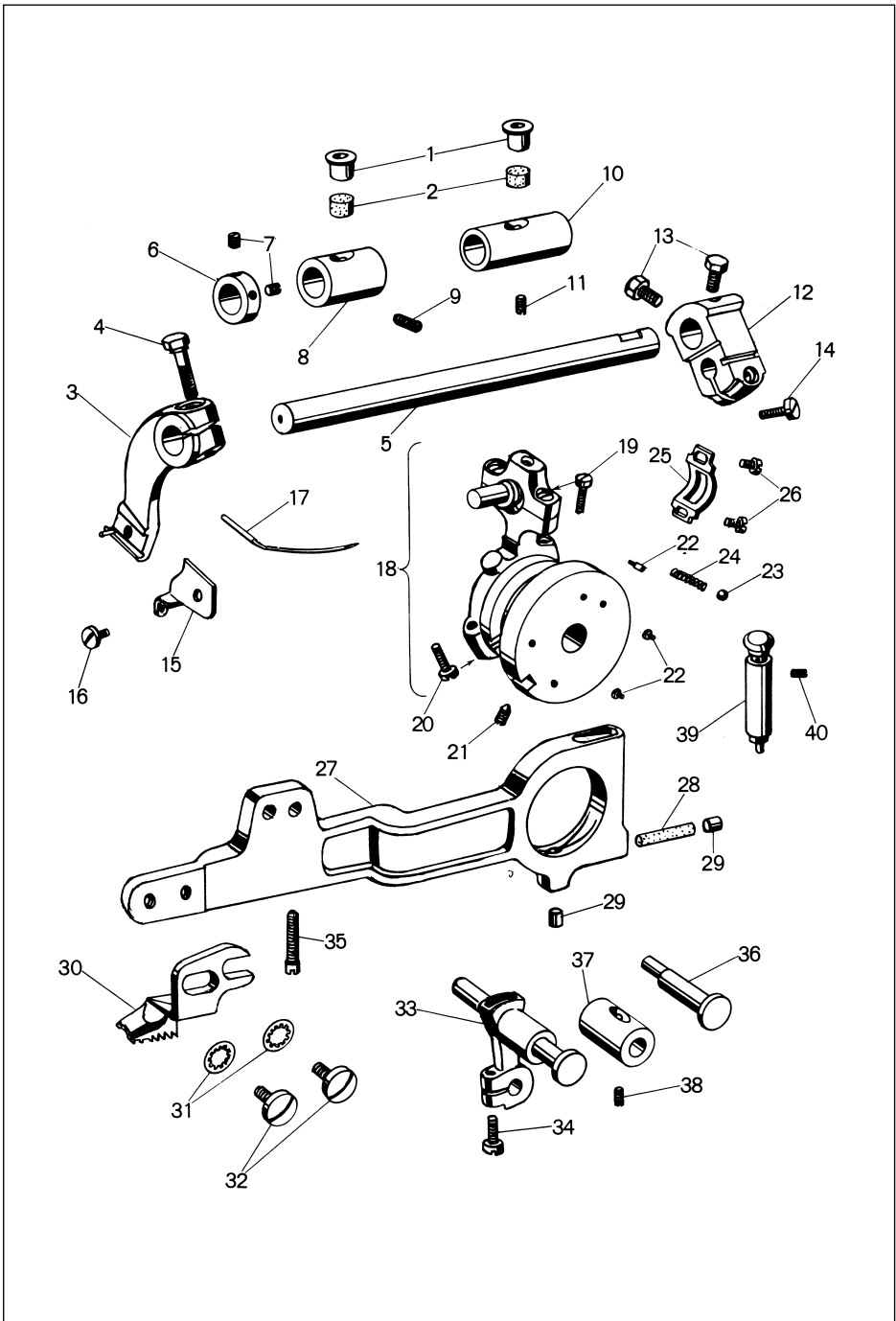

Needle Carrier & Feed Dog Mechanism Components

Ref. No.	Parts No.	Description
1	4128-A	Oil Cap
2	4217	Oiling Felt
3	4023-A	Needle Carrier
4	4024	Needle Carrier Set Screw
5	4019	Needle Carrier Shaft
6	4022	Needle Carrier Shaft Collar
7	129-B	Needle Carrier Shaft Collar Set Screw
8	4020-A	Needle Carrier Shaft Bushing (Front)
9	129-A	Needle Carrier Shaft Bushing Set Screw
10	4021-A	Needle Carrier Shaft Bushing (Rear)
11	129-A	Needle Carrier Shaft Bushing Set Screw
12	4017-A	Needle Carrier Shaft Crank
13	4018-A	Needle Carrier Shaft Crank Set Screw
14	114-A	Needle Carrier Shaft Crank Clamp Screw
15	11139	Needle Clamp
16	121	Needle Clamp Set Screw
17	4181	Needle (System LW x 6T)
18	1151	Needle Driving Eccentric Assembly w/Rod, Regulator & Screws (Ref. Nos. 19-22)
19	4211-C	Ball Connecting Rod Set Screw (Short)
20	4173	Ball Connecting Rod Set Screw (Long)
21	4009-B	Needle Driving Eccentric Set Screw
22	4012-A	Stitch Regulator Screw
23	4010	Stitch Regulator Ball
24	4011-A	Stitch Regulator Spring
25	4014	Ball Connecting Rod Cap
26	4015	Ball Connecting Rod Cap Set Screw
27	11902	Feed Lever
28	11124-J	Oiling Felt
29	11121	Oil Cap
30	10129	Feed Dog
31	2528	Feed Dog Washer
32	4048-A	Feed Dog Set Screw
33	1152-A	Feed Link & Stud
34	4173	Feed Link Clamp Screw
35	4042-A	Feed Link Stud Set Screw
36	4044	Feed Link Eccentric Stud
37	4043	Feed Link Eccentric Stud Bushing
38	129-A	Feed Link Eccentric Stud Bushing Set Screw
39	520-A	Stitch Length Regulating Plunger Assembly
40	129-A	Stitch Length Regulating Plunger Set Screw

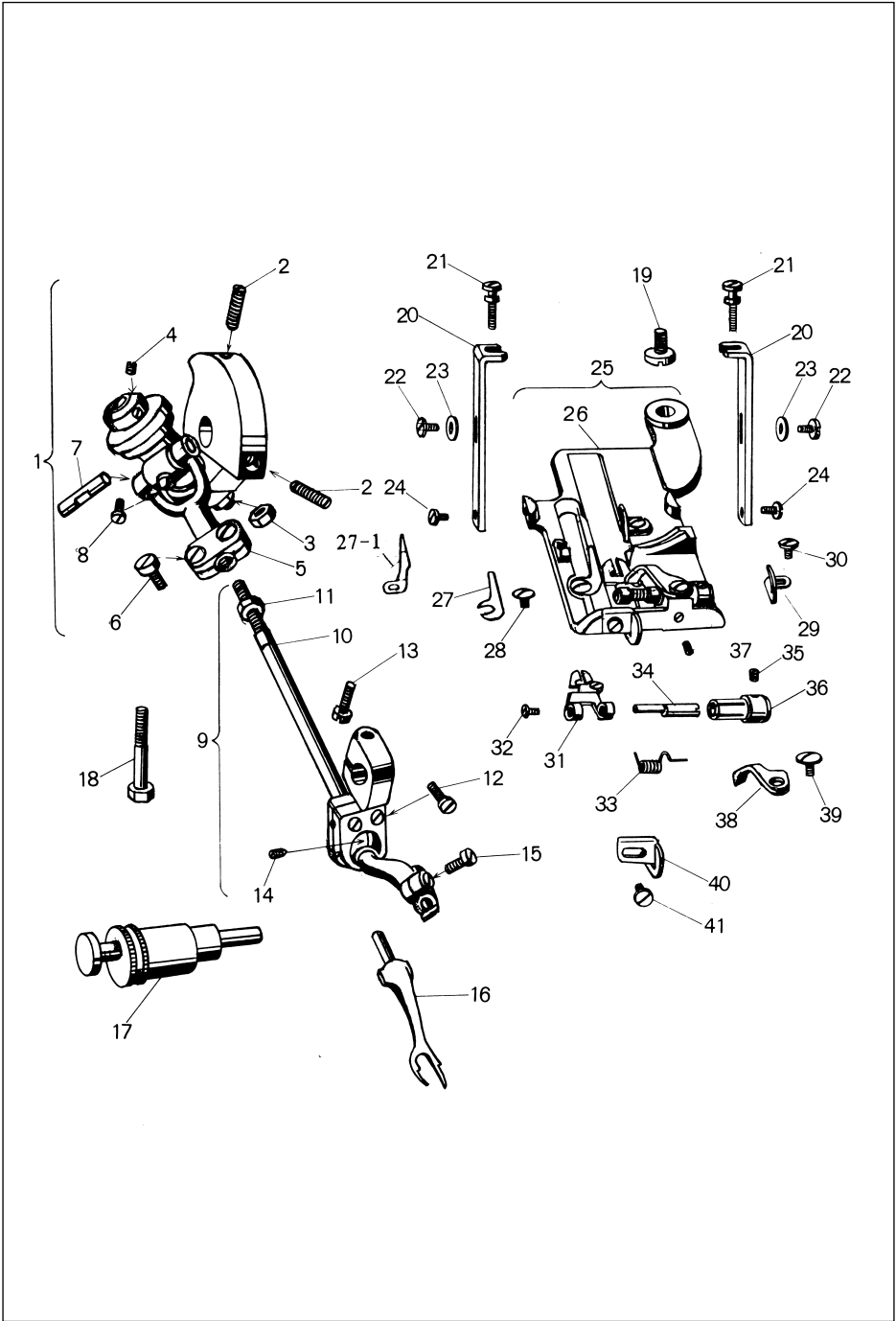

Looper Drive Mechanism & Presser Foot Parts Components

Ref. No.	Parts No.	Description
1	538-A	Looper Drive Crank Assembly w/Looper Yoke & Screws (Ref. Nos. 2-8)
2	4191	Looper Drive Crank Set Screw
3	5039-A	Looper Drive Crank Stud Nut
4	129-B	Looper Drive Crank Stud Collar Set Screw
5	4030-A	Looper Yoke
6	4031	Looper Yoke Set Screw
7	4032-A	Looper Yoke Pin
8	8142	Looper Yoke Pin Set Screw
9	539-A	Looper Carrier Assembly w/Ball Joint & Screws (Ref. Nos. 10-15)
10	4035-A	Looper Carrier
11	4176	Looper Carrier Nut
12	4216	Looper Carrier Ball Joint Set Screw
13	4213	Looper Carrier Ball Joint Clamp Screw
14	4179-D	Looper Carrier Ball Spot Screw
15	4040	Looper Clamp Screw
16	4039	Looper
17	505	Eccentric Sleeve & Pin
18	4038	Eccentric Sleeve Clamp Screw
19	4050	Presser Foot Set Screw
20	4061-A	Presser Foot Bracket
21	4062	Presser Foot Bracket Adjusting Screw
22	121-B	Presser Foot Bracket Holding Screw
23	11158	Presser Foot Bracket Washer
24	4186-A	Presser Foot Holding Screw
25	PF100	Presser Foot Assembly (Ref. Nos. 26-40)
26	4049-B	Plain Presser Foot
27	11563	Needle Guide
27-1	11563-A	Stitch Stabilizing Guide
28	4052-B	Needle Guide Set Screw
29	4058-A	Chaining Finger
30	4185	Chaining Finger Set Screw
31	4055CAS	Cloth Retainer
32	4185	Cloth Retainer Screw
33	4056	Cloth Retainer Spring
34	4054	Cloth Retainer Eccentric Stud
35	4183	Cloth Retainer Eccentric Stud Set Screw
36	4053	Cloth Retainer Eccentric Stud Bushing
37	130-B	Cloth Retainer Eccentric Stud Bushing Set Screw
38	4057-C	Cloth Retainer Stopper
39	4182	Cloth Retainer Stopper Set Screw
40	4059	Edge Guide
41	4185	Edge Guide Set Screw

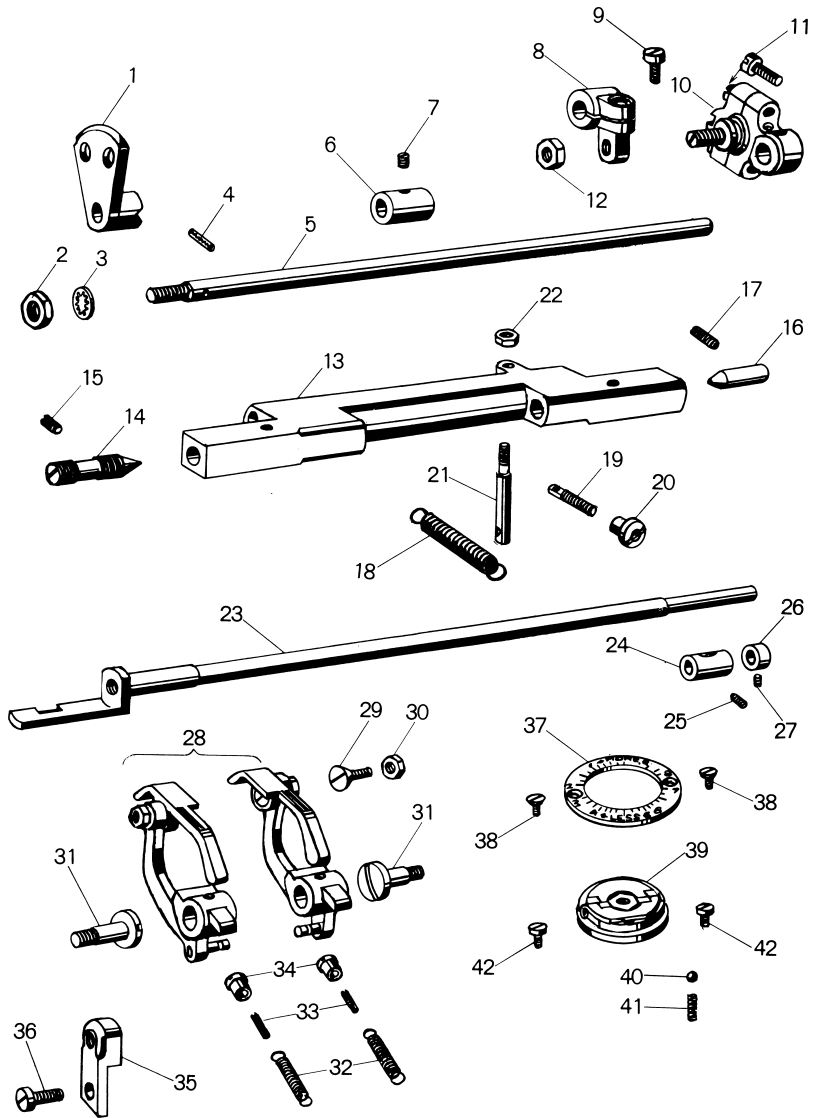

Ridge Forming Disc & Feed Plate Mechanism Components

Ref. No.	Parts No.	Description
1	11220-T	Ridge Forming Disc
2	4208	Ridge Forming Disc Nut
3	5222-B	Ridge Forming Disc Washer
4	8150	Ridge Forming Disc Positioning Pin
5	4109-A	Ridge Forming Disc Shaft
6	4111	Ridge Forming Disc Shaft Collar
7	129-B	Ridge Forming Disc Shaft Collar Set Screw
8	4112	Ridge Forming Disc Shaft Crank
9	113-B	Ridge Forming Disc Shaft Crank Set Screw
10	515-A	Ball Joint & Stud Assembly with Screws (w/Ref. No. 11)
11	108	Ball Joint Set Screw
12	4176	Ball Stud Nut
13	4102	Disc Adjusting Holder
14	4108	Disc Adjusting Holder Pivot Bearing Screw
15	98	Disc Adjusting Holder Pivot Bearing Screw Set Screw
16	4107	Disc Adjusting Holder Pivot Bearing Pin
17	98-A	Disc Adjusting Holder Pivot Bearing Pin Set Screw
18	4104	Disc Adjusting Holder Spring
19	4105	Disc Adjusting Holder Spring Screw
20	4106	Disc Adjusting Holder Spring Nut
21	4103-A	Disc Adjusting Holder Spring Stud
22	5208	Disc Adjusting Holder Spring Stud Nut
23	11075-A	Feed Plate Shaft
24	4043	Feed Plate Shaft Bushing
25	98	Feed Plate Shaft Bushing Set Screw
26	4090	Feed Plate Shaft Collar
27	129-B	Feed Plate Shaft Collar Set Screw
28	516-B	Feed Plate Assembly w/Screws & Nuts (Ref. Nos. 29, 30)
29	4101	Feed Plate Taper Bearing Screw
30	4070	Feed Plate Nut
31	4096	Feed Plate Shoulder Bearing Screw
32	4093-BA	Feed Plate Spring
33	4094	Feed Plate Spring Screw
34	4095	Feed Plate Spring Adjusting Nut
35	4097-A	Feed Plate Bracket
36	113-B	Feed Plate Bracket Set Screw
37	4122	Disc Adjusting Dial
38	4129	Disc Adjusting Dial Set Screw
39	519-AA	Disc Adjusting Regulator Assembly
40	4010	Disc Adjusting Regulator Ball
41	4011	Disc Adjusting Regulator Spring
42	115	Disc Adjusting Regulator Base Set Screw

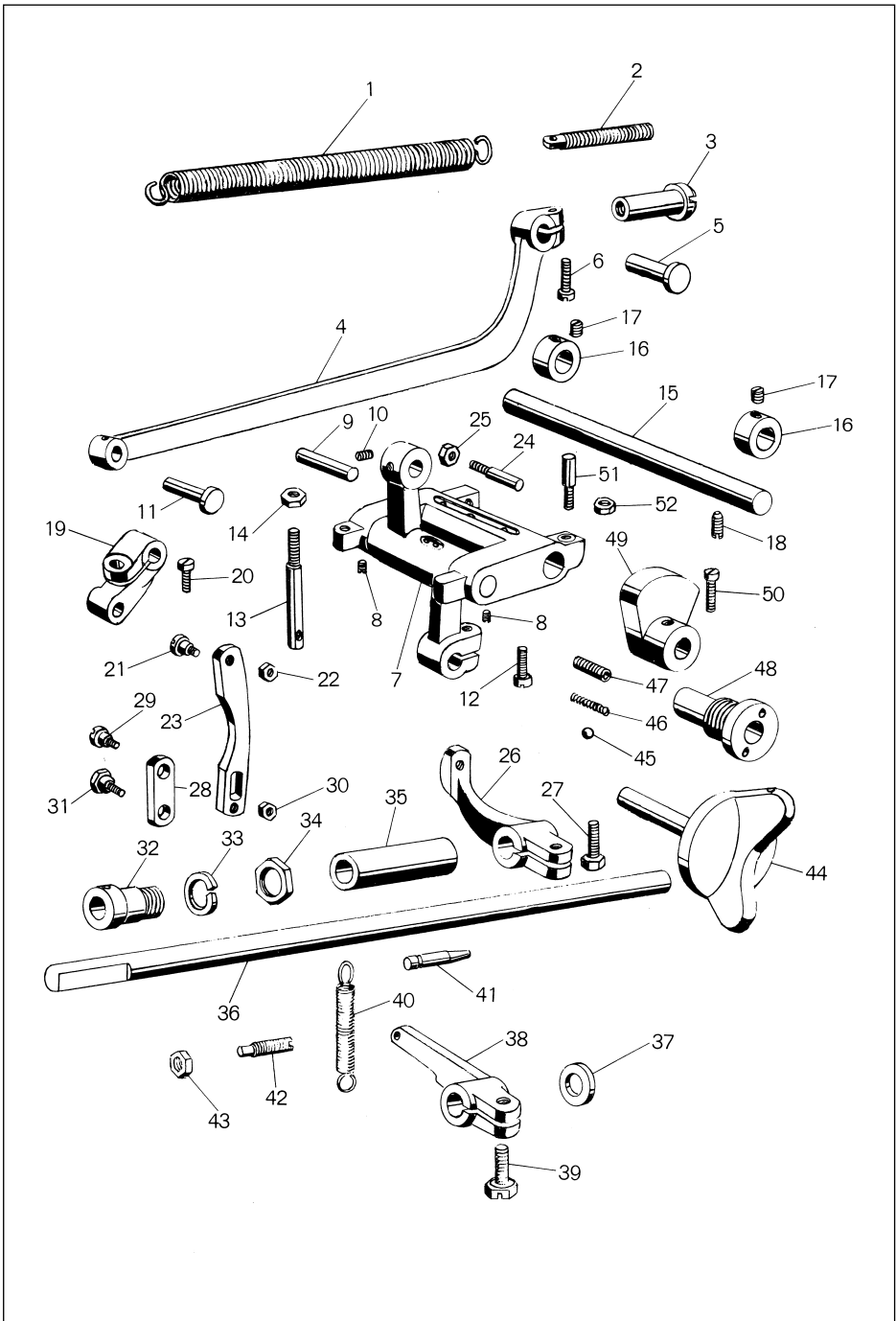

Disc Oscillating Mechanism & Knee Press Shaft Parts Components

Ref. No.	Parts No.	Description
1	4073-A	Disc Oscillating Rod Bracket Spring
2	4074	Disc Oscillating Rod Bracket Spring Screw
3	4075	Disc Oscillating Rod Bracket Spring Nut
4	4169	Connecting Rod
5	4065	Connecting Rod Stud
6	114-B	Connecting Rod Stud Set Screw
7	S-4066BB	Disc Oscillating Rod Assembly (w/Ref. No. 8)
8	129-B	Disc Oscillating Rod Shaft Set Screw
9	4115	Disc Oscillating Rod Pin
10	129-A	Disc Oscillating Rod Pin Set Screw
11	4065	Disc Oscillating Rod Stud
12	4031-A	Disc Oscillating Rod Stud Set Screw
13	4069-A	Disc Oscillating Rod Bracket Spring Stud
14	4070	Disc Oscillating Rod Bracket Spring Stud Nut
15	4076	Disc Oscillating Rod Bracket Shaft
16	4077-A	Disc Oscillating Rod Bracket Shaft Collar
17	132	Disc Oscillating Rod Bracket Shaft Collar Set Screw
18	131	Disc Oscillating Rod Bracket Shaft Set Screw
19	4098-A	Feed Plate Depressing Crank
20	105	Feed Plate Depressing Crank Set Screw
21	4178-A	Crank & Link Shoulder Screw
22	5207	Crank & Link Shoulder Screw Nut
23	4086	Connecting Link (Large)
24	4067-A	Connecting Link Guide Screw
25	4068 -A	Connecting Link Guide Screw Nut
26	4083	Knee Press Shaft Crank
27	4084	Knee Press Shaft Crank Set Screw
28	4087	Connecting Link (Small)
29	4088-A	Connecting Link Set Screw
30	5207	Connecting Link Set Screw Nut
31	4085	Crank & Link Shoulder Screw
32	4081-A	Knee Press Shaft Bushing
33	4206	Knee Press Shaft Bushing Washer
34	4205	Knee Press Shaft Bushing Nut
35	4177	Knee Press Shaft Sleeve
36	11063-A	Knee Press Shaft
37	11539	Knee Press Shaft Washer
38	4221	Knee Press Stop Lever
39	4084	Knee Press Stop Lever Clamp Screw
40	4222-A	Knee Press Stop Lever Spring
41	4116	Knee Press Stop Lever Spring Pin
42	11050	Knee Press Stop Lever Limit Screw
43	4068-A	Knee Press Stop Lever Limit Screw Nut
44	4171	Skip-Stitch Selecting Grip
45	4010	Skip-Stitch Selecting Ball
46	4011	Skip-Stitch Selecting Spring
47	4174	Skip-Stitch Selecting Spring Holder
48	4170	Skip-Stitch Selecting Grip Bushing
49	4172	Skip-Stitch Selecting Cam
50	4173	Skip-Stitch Selecting Cam Set Screw
51	4175-A	Skip-Stitch Selecting Cam Stud
52	4070-A	Skip-Stitch Selecting Cam Stud Nut

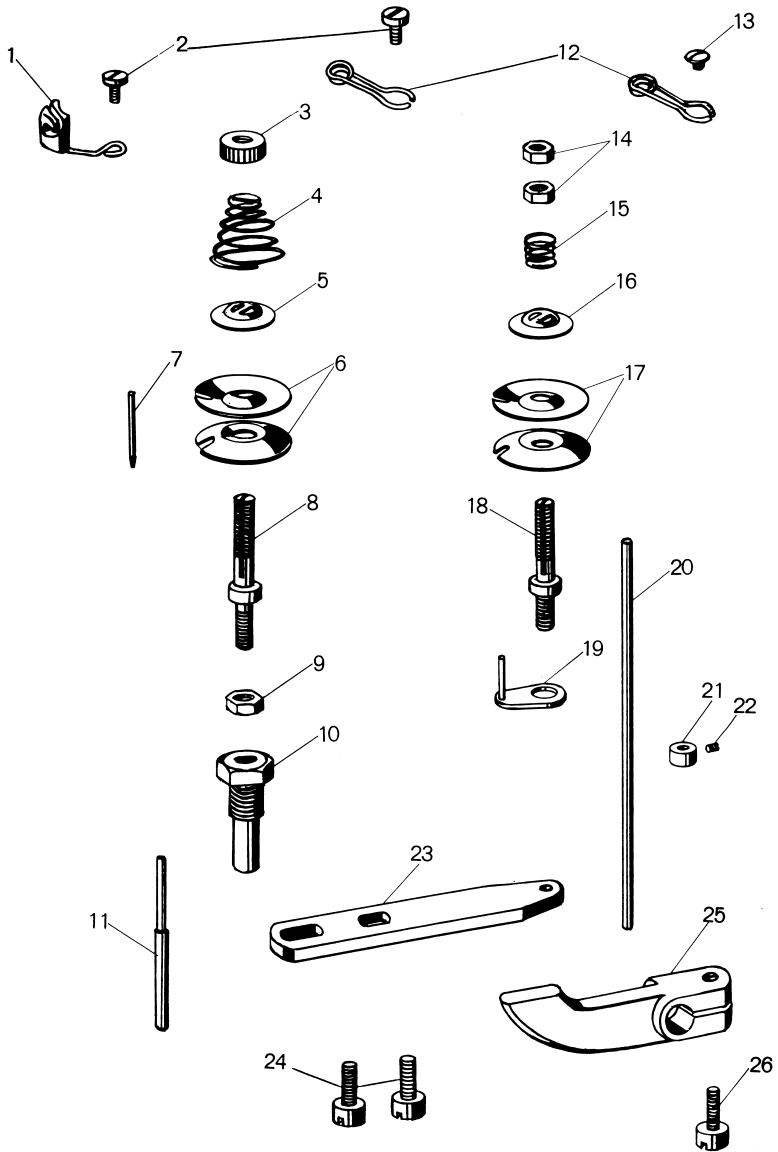

Thread Tension & Nipper Parts Components

Ref. No.	Parts No.	Description
1	11136	Thread Guide with Ceramic
2	113-A	Thread Guide Set Screw
3	81	Thread Tension Nut
4	79-B	Thread Tension Spring
5	77	Thread Tension Washer
6	5190-A	Thread Tension Disc
7	4204	Thread Tension Disc Pin
8	4209	Thread Tension Staff
9	4068-A	Thread Tension Staff Nut
10	4201	Thread Tension Staff Bracket
11	4202	Thread Tension Releasing Pin
12	4203-A	Thread Guide
13	4193	Thread Guide Set Screw
14	4199	Thread Nipper Nut
15	4198	Thread Nipper Spring
16	77	Thread Nipper Washer
17	5190-A	Thread Nipper Disc
18	5067	Thread Nipper Staff
19	4197	Thread Nipper Disc Prop
20	11162	Thread Nipper Releasing Pin
21	6053	Thread Nipper Releasing Pin Collar
22	130-B	Thread Nipper Releasing Pin Collar Set Screw
23	4195-C	Thread Nipper Releasing Pin Support
24	8158	Thread Nipper Releasing Pin Support Set Screw
25	4194-A	Thread Nipper Releasing Pin Lever
26	8158	Thread Nipper Releasing Pin Lever Set Screw

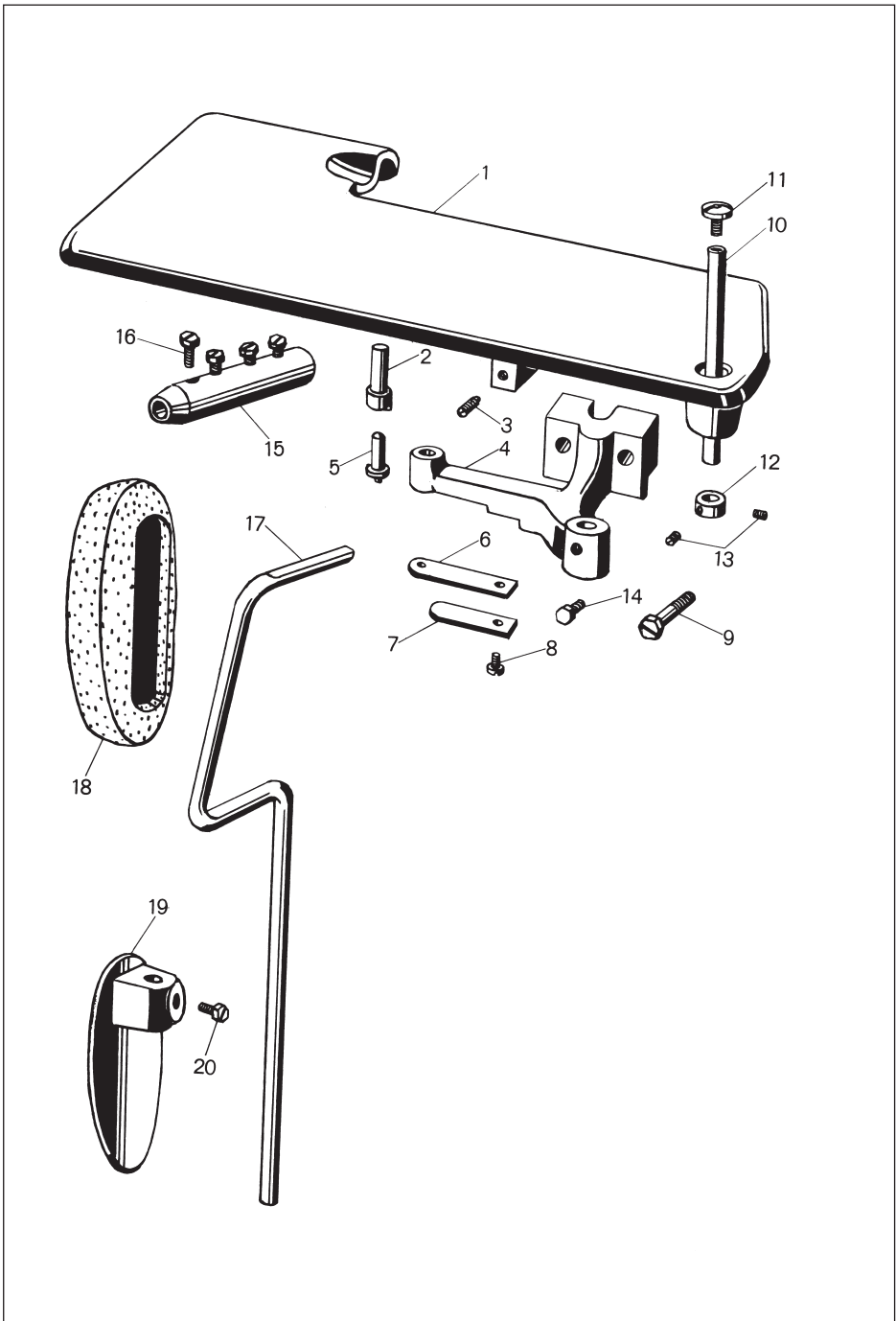

Work Plate, Knee Press & Belt Cover Parts Components

Ref. No.	Parts No.	Description
1	4153	Work Plate
2	4156	Work Plate Latch
3	5230	Work Plate Latch Set Screw
4	4157-A	Work Plate Bracket
5	4159	Work Plate Bracket Spring Pin
6	4160	Work Plate Bracket Leaf Spring (Long)
7	4161	Work Plate Bracket Leaf Spring (Short)
8	4048-A	Work Plate Bracket Leaf Spring Set Screw
9	4158	Work Plate Bracket Set Screw
10	4154-A	Work Plate Shaft
11	99-A	Work Plate Shaft Screwed Cap
12	4155	Work Plate Shaft Collar
13	132	Work Plate Shaft Collar Set Screw
14	4180	Work Plate Shaft Set Screw
15	4146-A	Knee Press Rod Sleeve
16	4147-B	Knee Press Rod Sleeve Set Screw
17	4148-A	Knee Press Rod
18	4212	Knee Press Pad
19	4149	Knee Press Plate
20	4147-B	Knee Press Plate Set Screw

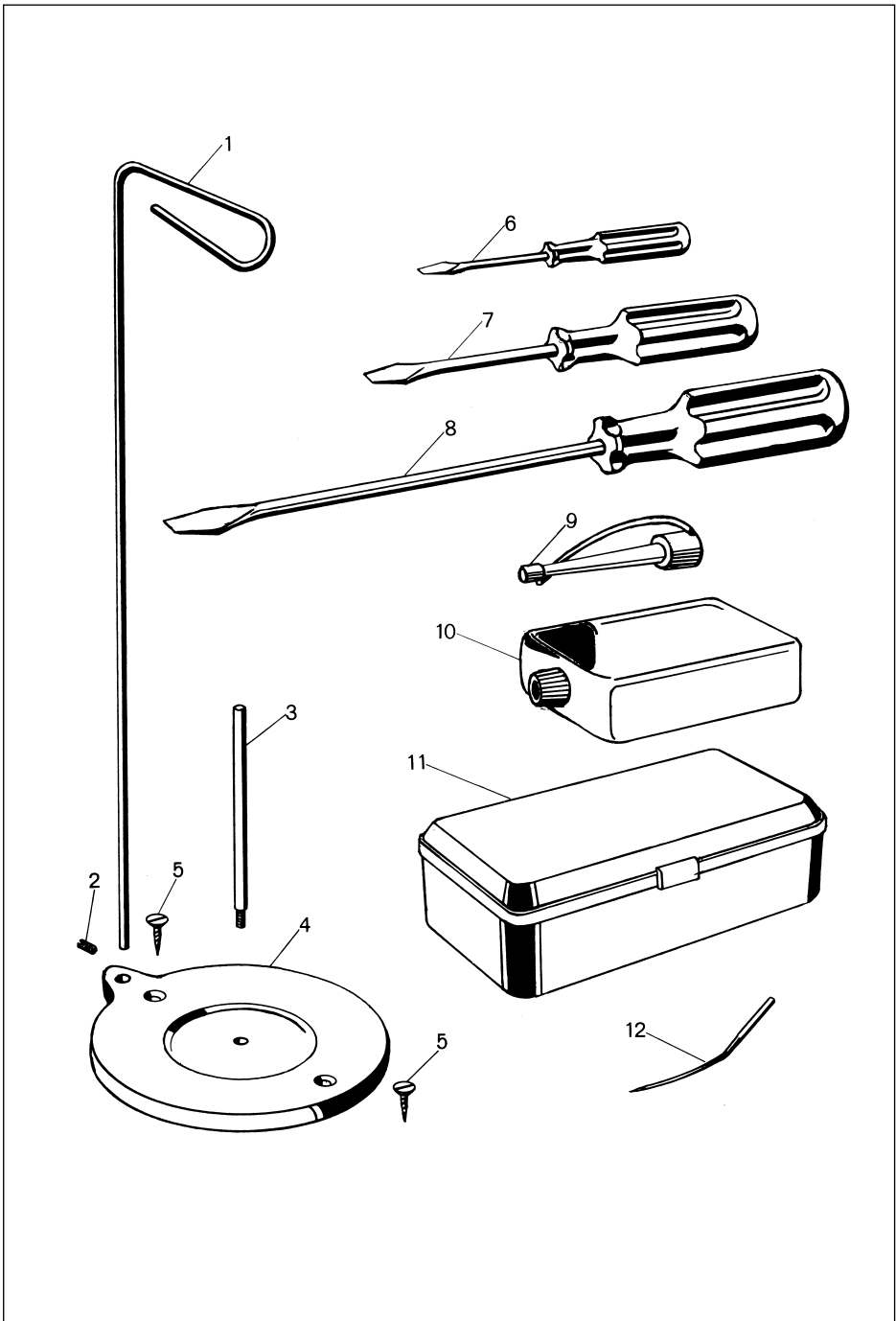

Standard Accessories

Ref. No.	Parts No.	Description
1	4152	Thread Guide
2	129-A	Thread Guide Set Screw
3	4151	Spool Pin
4	4150	Cotton Stand Base
5	AC-10	Cotton Stand Base Wood Screw
6	AC-03	Screw Driver (Small)
7	AC-02	Screw Driver (Medium)
8	AC-01	Screw Driver (Large)
9	AC-04A	Oiler
10	AC-05	Oil
11	AC-08	Accessory Box
12	4181	Needle (System LWx6T)

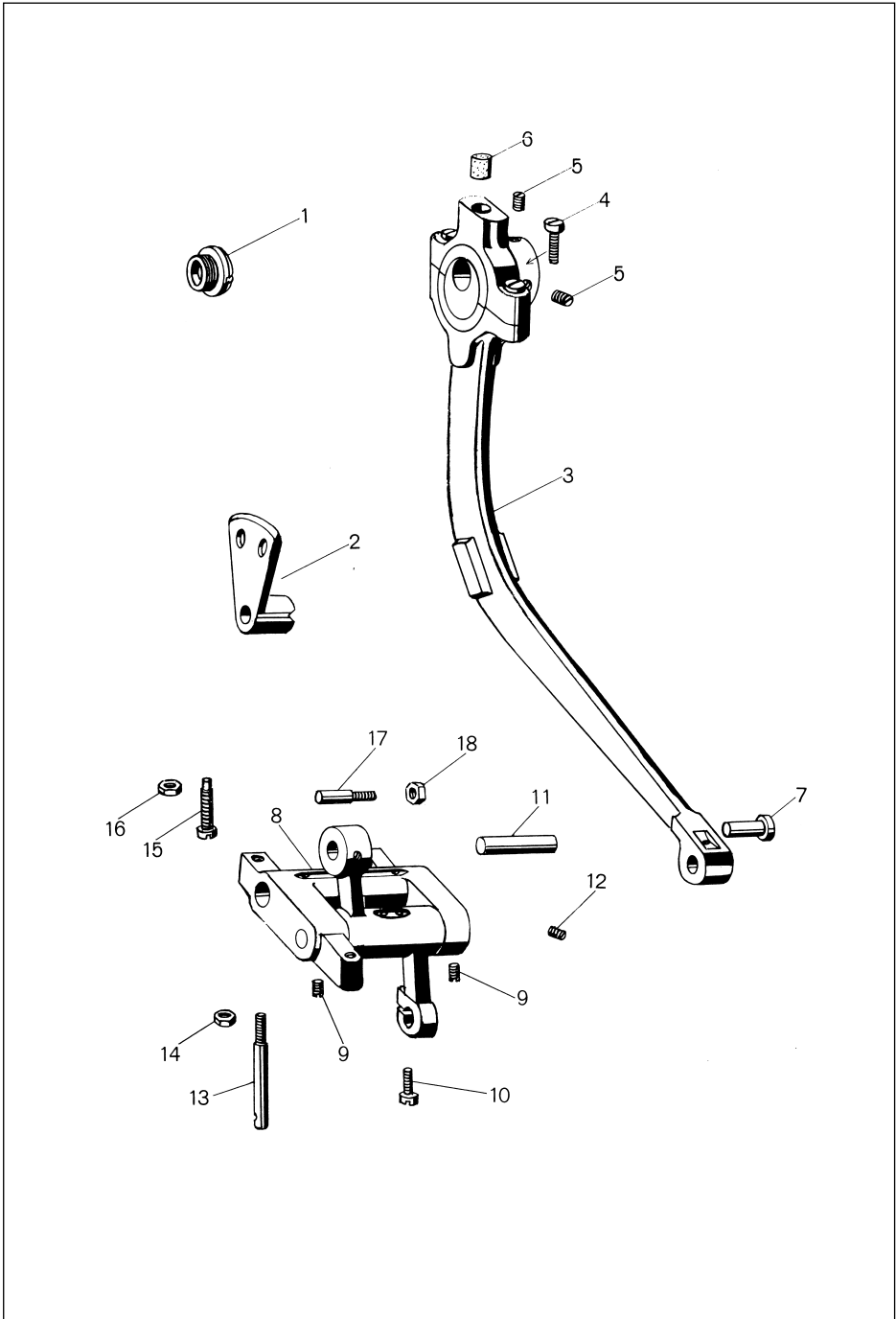

Additional Parts for Model H- 100 (Non-Skip Stitch)

Ref. No.	Parts No.	Description
1	4145	Screwed Cap (for hole of Grip 4171)
2	4110-AA	Ridge Forming Disc
3	507-A	Eccentric Rod Assembly (w/Ref. Nos. 4-6)
4	105	Eccentric Rod Set Screw
5	98	Eccentric Bushing Screw
6	4218	Oiling Felt
7	4065	Disc Oscillating Rod Stud
8	S-4066AB	Disc Oscillating Rod Assembly (w/Ref. No. 9)
9	129-B	Disc Oscillating Rod Shaft Set Screw
10	4031-A	Disc Oscillating Rod Stud Set Screw
11	4115	Disc Oscillating Rod Pin
12	129-A	Disc Oscillating Rod Pin Set Screw
13	4069-A	Disc Oscillating Rod Bracket Spring Stud
14	4070	Disc Oscillating Rod Bracket Spring Stud Nut
15	4078	Disc Oscillating Rod Bracket Adjusting Screw
16	4070	Disc Oscillating Rod Bracket Adjusting Screw Nut
17	4067-A	Connecting Link Guide Screw
18	4068-B	Connecting Link Guide Screw Nut

[Parts not listed are common to Model H-101 (See Pages 3 & 11).]

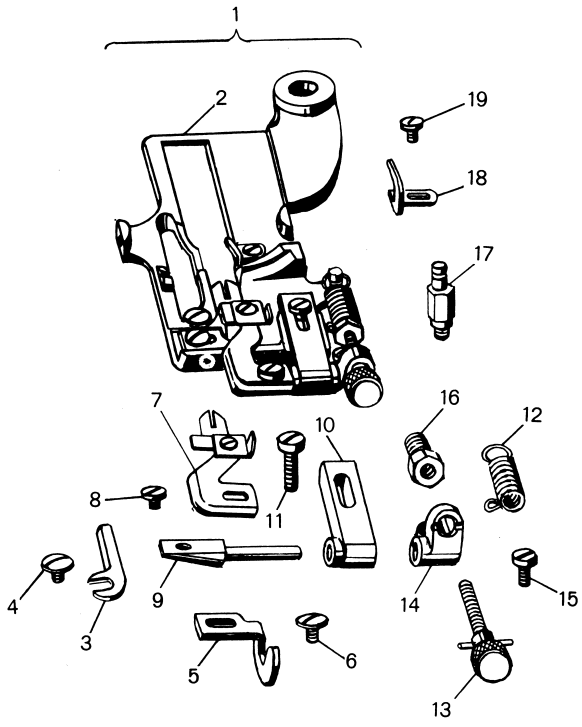

Additional Parts for Models H-101-H

Ref. No.	Parts No.	Description
1	PF100H	Universal Presser Foot Assembly (Ref. Nos. 2–19)
2	4301–C	Plain Universal Presser Foot
3	11563	Needle Guide
4	4052–B	Needle Guide Set Screw
5	4304	Edge Guide
6	4182–A	Edge Guide Set Screw
7	4302–S	Cloth Retainer
8	4308	Cloth Retainer Set Screw
9	10037	Cloth Retainer Holder
10	10038	Cloth Retainer Bracket
11	121	Cloth Retainer Bracket Set Screw
12	4312–A	Cloth Retainer Spring
13	10040	Cloth Retainer Spring Adjusting Screw
14	10039	Cloth Retainer Spring Adjusting Screw Prop
15	5233–A	Cloth Retainer Spring Adjusting Screw Prop Set Screw
16	4311–A	Cloth Retainer Spring Bushing
17	15128	Cloth Retainer Spring Pin
18	4058–A	Chaining Finger
19	4185	Chaining Finger Set Screw

Reliable Corporation ("Reliable") warrants to original purchaser of its products that every product sold by Reliable (a "Reliable Product") is free from defects in material and workmanship for a period of one year from the date of purchase if properly used and maintained. Subject to the conditions and limitations set forth below, Reliable will either repair or replace any part of a Reliable Product that proves defective by reason of improper workmanship or materials. If the defective Reliable Product is no longer available and cannot be repaired effectively or replaced with an identical model, Reliable shall replace the defective Reliable Product with a current Reliable Product of equal or greater value. Repaired parts or replacement products will be provided by Reliable on an exchange basis, and will be either new or refurbished to be functionally equivalent to new. If Reliable is unable to repair or replace a Reliable Product, it will refund the current value of that Reliable Product at the time the warranty claim is made.

This limited warranty does not cover any damage to a Reliable Product that results from improper installation, accident, abuse, misuse, natural disaster, insufficient or excessive electrical supply, abnormal mechanical or environmental conditions, wear and tear resulting from normal use of the product, or any unauthorized disassembly, repair, or modification. This limited warranty does not extend to any indirect, consequential or incidental damages that may be suffered by a user or from the use of a Reliable Product, including without limitation, any liability for third party claims for damage, and is limited to the amount paid by the original purchaser Reliable Product with respect to which this limited warranty protection applies. This limited warranty does not apply with respect to products that have been altered or which are missing serial numbers or for products not purchased directly from Reliable or a dealer authorized by us to sell Reliable Products.

This limited warranty is the only warranty that applies to any Reliable Product, supersedes any and all terms that may be contained in any other document or purchase order and may not be altered or amended except expressly in writing by Reliable.

To obtain a repair or replacement under the terms of this warranty, please contact our customer service group at 1-800-268-1649 or at support@reliablecorporation.com. You will be required to submit an original receipt via fax or e-mail. The receipt must reflect that you are the original purchaser, the product was bought directly from us or from an authorized Reliable dealer and that the warranty claim is being made within the warranty period. You will be issued a return authorization number (RA#) and asked to ship the defective product together with proof of purchase and RA#, prepaid insured to the following address:

Reliable Corporation, 5-100 Wingold Avenue, Toronto, ON M6B 4K7. Freight collect shipments will be refused. The risk of loss or damage in transit will be borne by the customer. Once Reliable receives the defective product, it will initiate the repair or replacement process.

If you have any questions regarding this warranty, you may write to:

Reliable Corporation
100 Wingold Avenue, Unit 5
Toronto, Ontario
Canada M6B 4K7
www.reliablecorporation.com



1 800 268 1649
www.reliablecorporation.com