



8000 Series

Professional Steam Boilers

The 8000
Professional Steam Boilers
Instruction Manual
English



Do Not Return To Store
Contact Us First

For immediate help with your purchase, please give us a call so that we can resolve your issue.

We can be reached toll-free at 1-800-268-1649 or email support@reliablecorporation.com

Reliable. Getting it Right. For You.

At Reliable, we do what we love, and we take pride in doing it right. You want what's best for the people, places and things that matter in your life—from where you live to what you wear. So do we. That's why we approach every product with a laser-focus on you. In our commitment to quality, functionality, design and customer service, we are continuously innovating to find solutions to better fit your needs. Everything we make looks and feels just right, because it is. We get it right. For you.

For your safety and to fully enjoy the advantages of this product, please take a few minutes to read all the important safeguards and care instructions. Keep this manual handy and review the product warranty for your reference.

Thank you for your purchase. Please share your Reliable product experience by posting an online review on the website from which you purchased. We greatly appreciate it.

Specifications

8000BU

Electrical 120V/20 amps

Steam Capacity Unlimited

Boiler Capacity 1.25 GAL / 4.5L

Operating Pressure Up to 58PSI / 4 BAR

Plug NEMA 5-20 

Wattage 2000W (Boiler 1200W + Iron 800W)

Tank Construction Stainless Steel

Warranty Limited 1 year, 2 years boiler tank

Country of Origin Italy

8000CJ/CD

Electrical 120V/10 amps

Steam Capacity Unlimited

Boiler Capacity 1.25 GAL / 4.5L

Operating Pressure Up to 58PSI / 4 BAR

Steam Temperature 221°F / 105 °C

Plug NEMA 5-15 

Tank Construction Stainless Steel

Wattage 1200W

Warranty Limited 1 year, 2 years boiler tank

Country of Origin Italy

8000BU

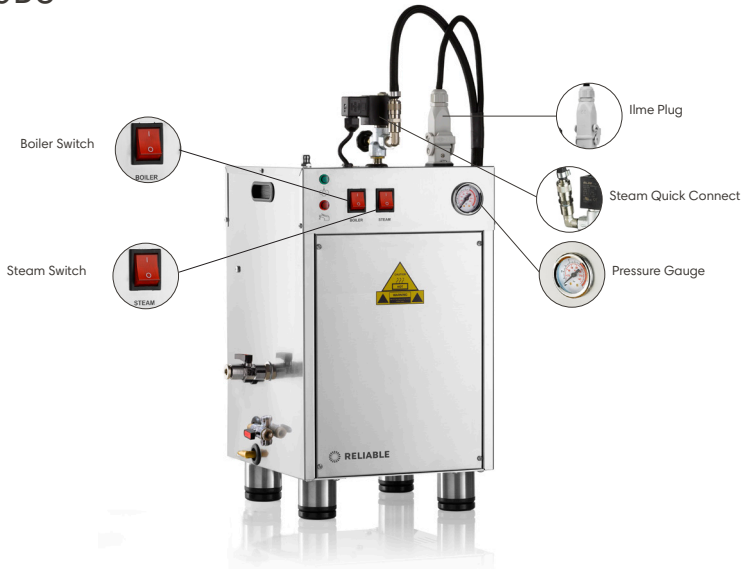
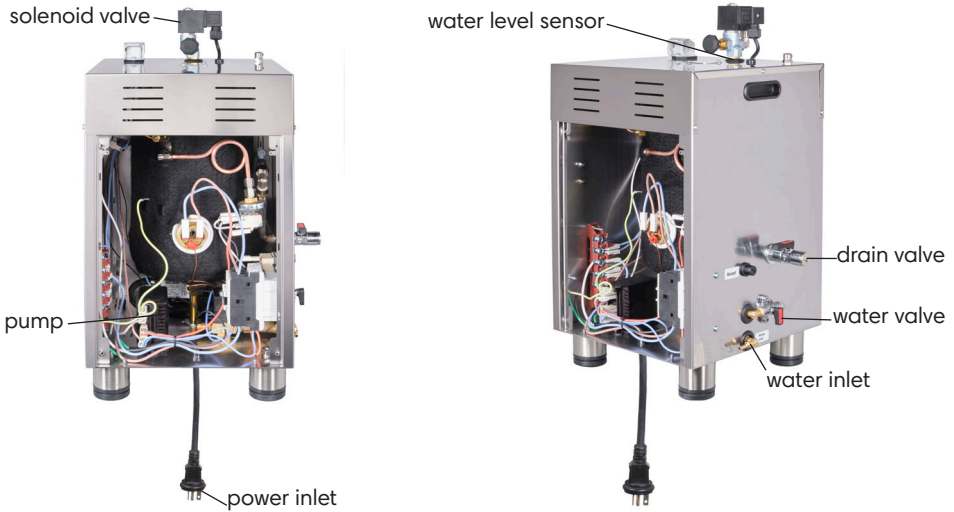

Fig. 5



The installation and use of this professional equipment must be done by competent and trained personnel with appropriate technical knowledge and understanding of applicable safety standards.

Unboxing

Remove the Boiler from the box, affix the wands, connect iron sockets and steam tubes, fix the iron cable to cable/steam wand support hook.

Attention: Irons must be placed on their iron rests, on the ironing board.

Iron Assembly (For the 8000BU/4100IR)

1. Remove iron from packaging.
2. It is recommended to put the iron on the iron pad (supplied), as the pad will withstand the temperature of the iron.
3. Connect the Iron to the Ilme plug and the Steam Quick Connect on the boiler. Turn the lock until it clicks to ensure full connection.



Foot Pedal Assembly (For the 8000CJ)

1. Remove foot pedal from packaging.
2. Connect the foot pedal to the Ilme plug. Turn the lock until it clicks to ensure full connection.



Steam Gun Assembly (For the 8000CD)

1. Remove steam gun from packaging.
2. Insert the Steam Cord Holder into the flange on top of the boiler and attach the spring on the steam hose to the coil end of the wand.
3. Connect the steam gun to the Ilme plug. Turn the lock until it clicks to ensure full connection.

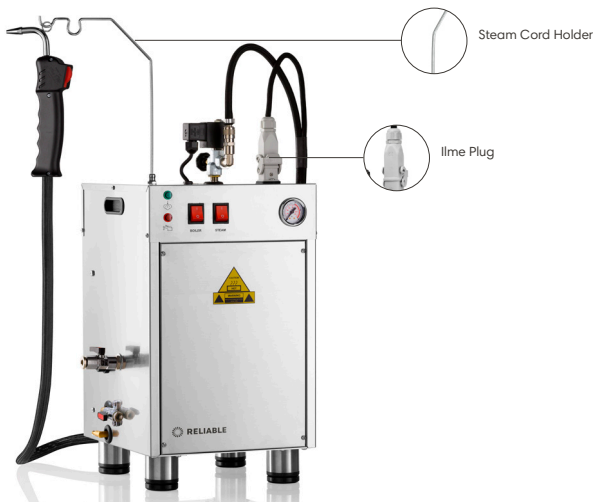

Boiler Setup and Operations Instructions

Initial Setup: Water Connection Options

Using the Direct Water Feed:

1. Connect the water feed to the water inlet (Fig. 5 #1) using a 1/4-inch ID clear vinyl tubing.
2. Use an SAE size 4 clamp to secure the tubing.
3. Ensure the water valve (Fig. 5 #6) is closed when using a direct water feed.

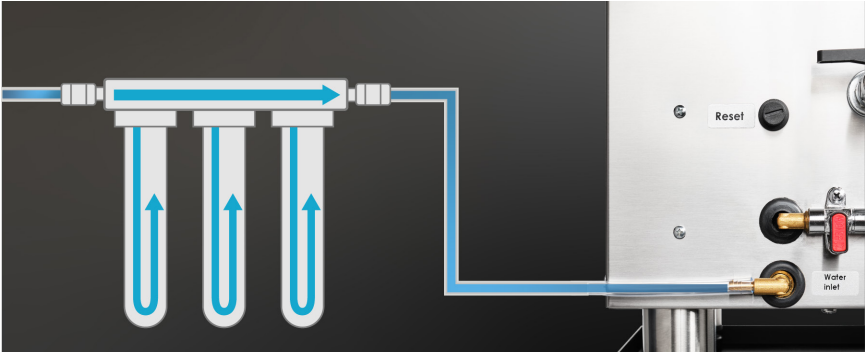

Using the External Water Container Kit:

1. Attach the water container to the water inlet (Fig. 5 #1) using 1/4-inch ID clear vinyl tubing.
2. Secure the tubing with an SAE size 4 clamp.
3. Fill the container with water (the bucket is sold separately for the 8000 series).
4. Open the water valve (Fig. 5 #6) to allow water flow to the boiler.

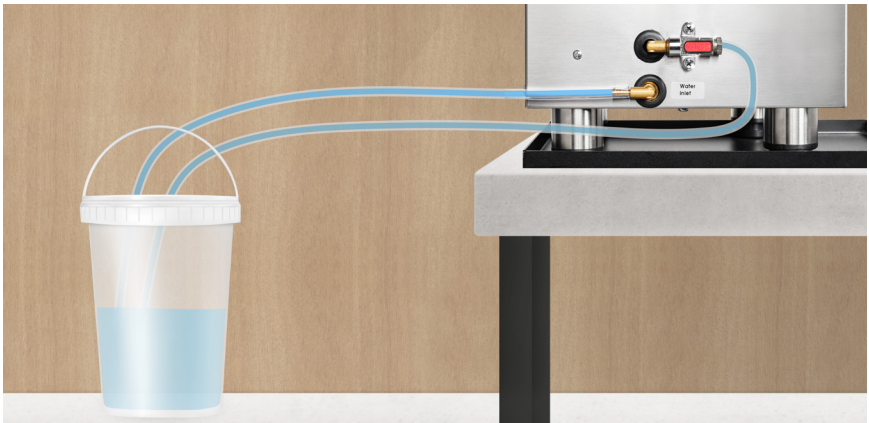

Note: Optional 9000BUWC, 2 gallon water container sold separately

Powering On the Boiler:

1. Insert the plug into the electrical outlet. It is not recommended to use an extension cord with your boiler. Using an extension cord can reduce the life of your unit. If required, do not use more than 6' and ensure it is a 14-gauge wire.
2. Press the Boiler switch to the ON position. The red light will illuminate to indicate the unit is powered on. You may also switch on the steam function, but steam will only be generated once the unit reaches maximum pressure.
3. Allow approximately 20 minutes for the boiler to reach maximum pressure. During heating, the green light will remain OFF. Once the boiler reaches pressure, the green light will turn ON (it may cycle on and off depending on pressure).

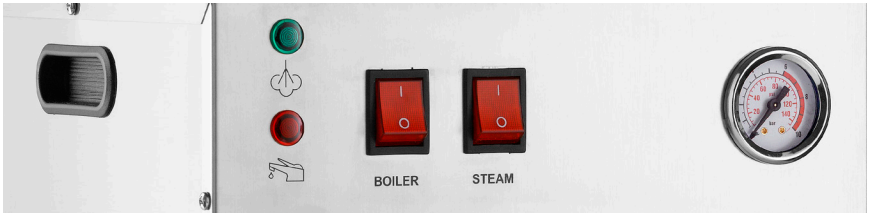

Boiler Activation:

1. Ensure the boiler reaches between 50–60 PSI. Once this pressure is achieved, the boiler is ready for use.
2. Before beginning work, press the steam button or foot pedal 3–4 times to warm the steam line. The first few activations may release condensation, which can appear as water droplets—this is normal. Repeating this step helps clear the line and ensures consistent steam delivery.
3. Regulate the steam flow to your iron, steam gun or nozzle.

Note: When you activate steam for the first time after turning the boiler on, you may notice a rapid drop in pressure. This is normal and only occurs during the initial use.



Ongoing Operation:

1. The “steam ready” light will switch on and off to indicate the boiler’s status.
2. Always ensure there is enough water for the steam generator. The lack of water will cause the pump to run for about a minute before sounding an alarm and automatically shutting down the unit.

Important

1. Use only tap water. **Do not use distilled water.**
2. Always ensure the steam iron is held properly and safely to avoid injury.
3. If using the direct water feed, the valve must remain closed. When using the external water container kit, always open the valve to allow water to flow.
4. Without water, the pump will run for about a minute, after which an alarm will sound, and the unit will automatically shut down.
5. Flush the Boiler once a week, making sure that the unit is shut off. Open the drain valve slowly (water discharge). During this operation wear appropriate regulation gloves, in order to avoid burns.
6. Never leave hot iron on the ironing board.
7. Connect the Boiler to suitable protected plug.
8. Only for the units connected to the direct waterfeed: When not in use, switch the Boiler off and close the water tap; remember to open the water tap before switching on the machine again.
9. Always keep children away from the Boiler, both when it is on and off.
10. Make sure that during cold seasons the tubes that connect the Boiler to water supply do not freeze.
11. Do not put additives in the water.
12. Repair must be carried out by authorized personnel and all the components must be replaced only with original spare parts.
13. Water pressure should never go over 50 PSI, otherwise the pump will stop and the water will not reach the Boiler.

Water Level Probe Cleaning Procedure

We recommend you clean the water level probe once a month. This cleaning operation must be carried out **only** by authorized personnel. Before you begin, please ensure that the unit is unplugged and at 0 PSI.

Please follow the cleaning instructions as indicated below:

1. Remove the two screws from the access panel located in the centre of the top cover. Then, proceed to remove the access panel (Fig 5, #7).
2. Locate the terminal connection to the water level probe.
3. Disconnect the wire from the water level probe terminal connection.
4. Use a 19mm deep socket to turn the probe counterclockwise until it can be removed. Ensure the teflon seal on the water sensor remains intact and on the probe.
5. Clean the probe using melamine foam. Once complete, reinsert the probe into tank.
6. Use a 19mm deep socket to turn the probe clockwise until snug. Do not overtighten.
7. Reconnect the wire to the terminal connection of the water level probe. Ensure the connection is tight. If the connection is loose, disconnect and then gently crimp the terminal connector on the wire with pliers until fit is snug.
8. Reinstall the access panel with its two mounting screws.

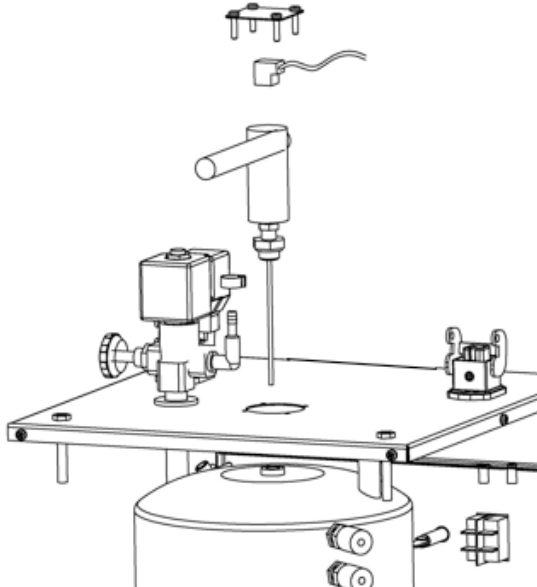

Important Information for Correct Disposal of the Product

This product must not be disposed of as urban waste. It must be taken to a special local waste collection centre or to a dealer providing this service.

8000BU

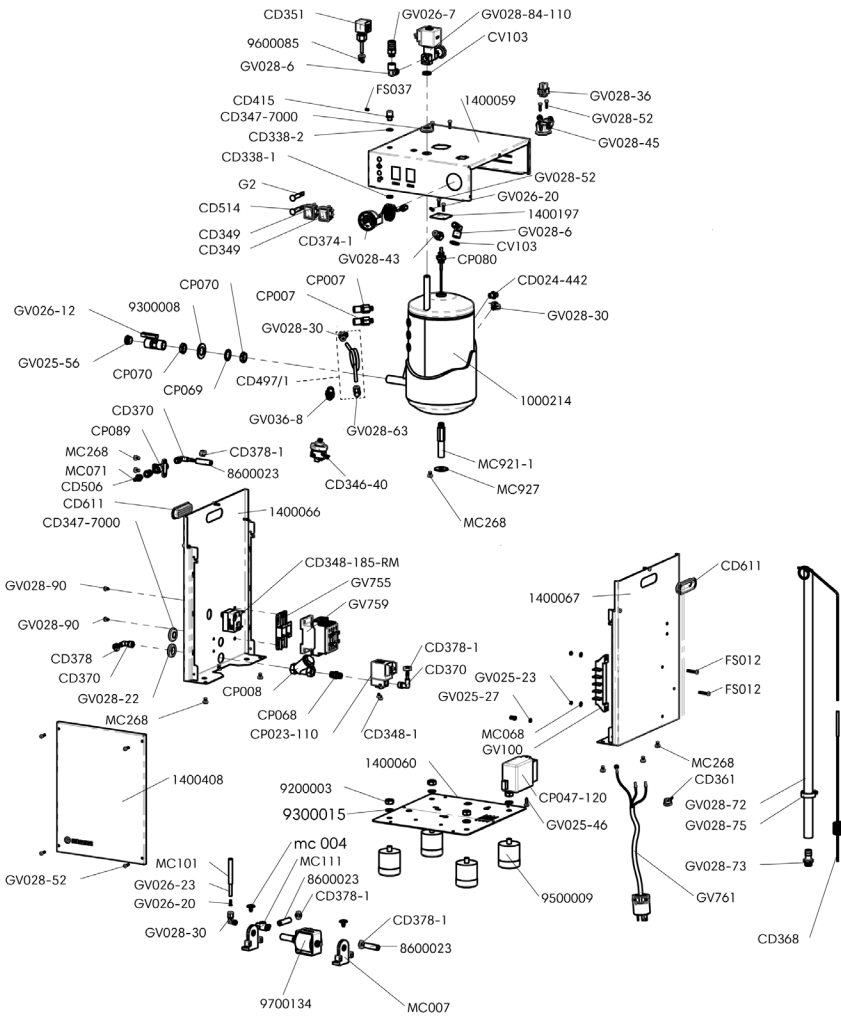

*

- Foot Pedal – GV028/71 (8000CJ)
- Steam Nozzle – GV028/67 (8000CJ)
- Steam Gun – 3000DA (8000CD)

At End of Day:

Releasing Steam Pressure

To prolong the life of the boiler and its components, we recommend that this task be performed at the end of the day.

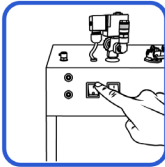

1. Turn off the boiler switch.

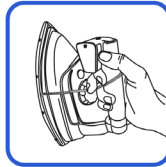

2. Press the steam button on the iron until the pressure drops to zero.

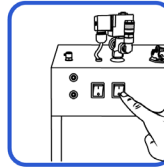

3. To complete the shutdown of the boiler, turn the steam switch off.

Every Week:

Flushing the Boiler Out

To prevent limescale deposits, the boiler should be drained every week.



1. Should be completed in the morning or when the boiler is cold with zero pressure.

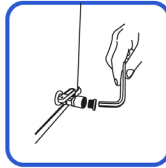

2. Remove the plug (using an 8mm allen key) from the drain valve.

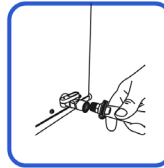

3. Attach the supplied clear drain hose to the drain valve.

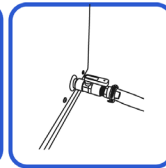

4. Open the drain valve and allow the water to be emptied into a large container.

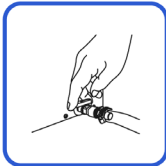

5. When completely emptied, close the drain valve.

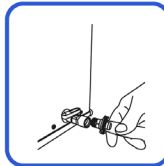

6. Remove the hose and reattach the plug at the end of the drain valve.

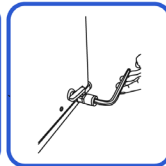

7. The unit is now ready to be filled with water.

At End of Day:

Releasing Steam Pressure

To prolong the life of the boiler and its components, we recommend that this task be performed at the end of the day.



1. Turn off the boiler switch.



2. Press the steam button on the steam gun until the pressure drops to zero.

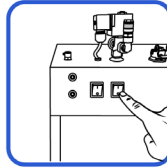

3. To complete the shutdown of the boiler, turn the steam switch off.

Every Week:

Flushing the Boiler Out

To prevent limescale deposits, the boiler should be drained every week.



1. Should be completed in the morning or when the boiler is cold with zero pressure.

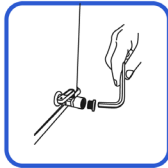

2. Remove the plug (using an 8mm allen key) from the drain valve.

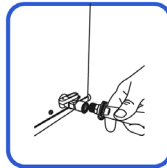

3. Attach the supplied clear drain hose to the drain valve.

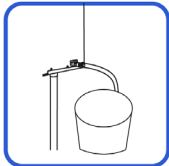
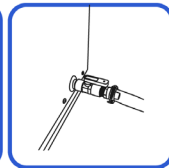

4. Open the drain valve and allow the water to be emptied into a large container.



5. When completely emptied, close the drain valve.

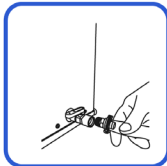

6. Remove the hose and reattach the plug at the end of the drain valve.

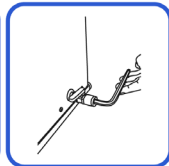

7. The unit is now ready to be filled with water.

At End of Day:

Releasing Steam Pressure

To prolong the life of the boiler and its components, we recommend that this task be performed at the end of the day.



1. Turn off the boiler switch.

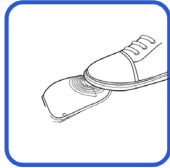

2. Press the pedal until the pressure drops to zero.

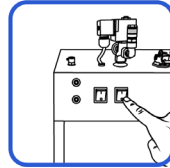

3. To complete the shutdown of the boiler, turn the steam switch off.

Every Week:

Flushing the Boiler Out

To prevent limescale deposits, the boiler should be drained every week.



1. Should be completed in the morning or when the boiler is cold with zero pressure.

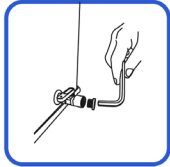

2. Remove the plug (using an 8mm allen key) from the drain valve.

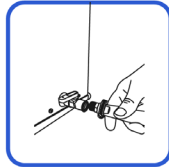

3. Attach the supplied clear drain hose to the drain valve.

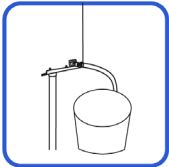
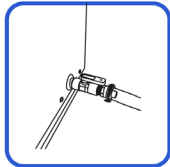

4. Open the drain valve and allow the water to be emptied into a large container.

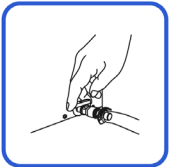

5. When completely emptied, close the drain valve.

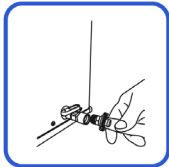

6. Remove the hose and reattach the plug at the end of the drain valve.

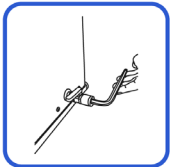

7. The unit is now ready to be filled with water.

Reliable Corporation (“Reliable”) provides a limited warranty for your new Reliable Steam Boiler. Reliable warrants the New Reliable Steam Boiler against defects in materials and workmanship for **1 year** from the original purchase date.

Inner Boiler Tank Warranty: The inner boiler tank is covered against leakage for **2 years** from the original purchase date.

What’s Covered

If your boiler or inner tank is found to be defective within the warranty period, Reliable will repair or replace the unit at no cost to you (subject to terms outlined below).

- **Boiler Repair:** If defects are reported within the first year, Reliable will repair the boiler at no cost.
- **Inner Tank Replacement:**
 - Year 1:** If a defect is found in the inner tank, Reliable will replace it at no charge.
 - Year 2:** If a defect is reported in the second year, Reliable will replace the inner tank, but the shipping costs will not be covered.

What’s Not Covered

This warranty does not cover:

- **Improper Installation:** Any issues caused by incorrect installation, damage from wear and tear, or accidents.
- **Misuse:** Damage due to improper use, natural disasters, electrical issues, or unauthorized repairs or modifications.
- **Indirect Damages:** Any indirect, incidental, or consequential damages, including claims from third parties.
- **Altered Products:** Any product that has been altered, lacks a serial number, or was not purchased directly from Reliable or an authorized dealer.

Warranty Claim Process

To file a warranty claim:

- Contact Reliable Customer Service at **1-800-268-1649** or **support@reliablecorporation.com**
- Provide proof of purchase (receipt showing original purchaser and authorized seller).
- If your claim is accepted, you will receive a **Return Authorization Number (RA#)**
- Ship the defective product, with proof of purchase and RA#, prepaid and insured, to:
Reliable Corporation, 5-100 Wingold Ave, North York, Ontario, M6B 4K7, Canada

Freight collect shipments will be refused. Customers are responsible for the risk of loss or damage in transit.

It overrides any other terms, unless otherwise agreed in writing by Reliable.

This warranty applies to products used for personal, and not commercial or rental, service. Reliable is not liable for incidental or consequential damages of any nature associated with the use of this product. Reliable's liability will not exceed the purchase price of the product.

For questions, contact:

Reliable Corporation
100 Wingold Avenue, Unit 5
Toronto, Ontario
Canada M6B 4K7
www.reliablecorporation.com



1 800 268 1649
www.reliablecorporation.com

24032025